



# PROTEUS<sup>TM</sup> LUCIUS

user manual

©2020 ELATION PROFESSIONAL all rights reserved. Information, specifications, diagrams, images, and instructions herein are subject to change without notice. ELATION PROFESSIONAL logo and identifying product names and numbers herein are trademarks of ELATION PROFESSIONAL. Copyright protection claimed includes all forms and matters of copyrightable materials and information now allowed by statutory or judicial law or hereinafter granted. Product names used in this document may be trademarks or registered trademarks of their respective companies and are hereby acknowledged. All non-ELATION brands and product names are trademarks or registered trademarks of their respective companies.

**ELATION PROFESSIONAL** and all affiliated companies hereby disclaim any and all liabilities for property, equipment, building, and electrical damages, injuries to any persons, and direct or indirect economic loss associated with the use or reliance of any information contained within this document, and/or as a result of the improper, unsafe, insufficient and negligent assembly, installation, rigging, and operation of this product.

**Elation Professional USA | 6122 S. Eastern Ave. | Los Angeles, CA. 90040**  
323-582-3322 | 323-832-9142 fax | [www.elationlighting.com](http://www.elationlighting.com) | [info@elationlighting.com](mailto:info@elationlighting.com)

**Elation Professional B.V. | Junostraat 2 | 6468 EW Kerkrade, The Netherlands**  
+31 45 546 85 66 | +31 45 546 85 96 fax | [www.elationlighting.eu](http://www.elationlighting.eu) | [info@elationlighting.eu](mailto:info@elationlighting.eu)

**Elation Professional Mexico | AV Santa Ana 30 | Parque Industrial Lerma, Lerma, Mexico 52000**  
+52 (728) 282-7070

## DOCUMENT VERSION



Due to additional product features and/or enhancements, an updated version of this document may be available online. Please scan the QR Code with your mobile device or visit [www.elationlighting.com](http://www.elationlighting.com) for the latest revision/update of this manual, before installation and/or programming.

Date	Document Version	SoftwareVersion ≥	DMX Channel Modes	Notes
08/25/2020	1.0	1.3.0	43 / 68	Initial Release

# CONTENTS

<b>General Information</b>	<b>4</b>
<b>Limited Warranty (USA Only)</b>	<b>5</b>
<b>Safety Guidelines</b>	<b>6</b>
<b>Maintenance Guidelines</b>	<b>8</b>
<b>Fixture Overview</b>	<b>9</b>
<b>Colors and Gobos</b>	<b>10</b>
<b>Custom Gobos</b>	<b>11</b>
<b>Gobo Installation</b>	<b>14</b>
<b>Torque Settings for Screws</b>	<b>15</b>
<b>Installation Guidelines</b>	<b>16</b>
<b>System Menu</b>	<b>23</b>
<b>Dimmer Curve</b>	<b>30</b>
<b>DMX Channel Functions and Values</b>	<b>31</b>
<b>Error Codes</b>	<b>41</b>
<b>Specifications</b>	<b>42</b>
<b>Dimensional Drawings</b>	<b>43</b>
<b>Optional Accessories</b>	<b>45</b>

# GENERAL INFORMATION

## INTRODUCTION

Please read and understand the instructions in this manual carefully and thoroughly before attempting to operate this device. These instructions contain important safety and use information.

## IP65 RATED

An IP rated lighting fixture is one, which is commonly installed in outdoor environments and has been designed with an enclosure that effectively protects the ingress (entry) of external foreign objects such as dust and water. **The International Protection (IP)** rating system is commonly expressed as "**IP**" (Ingress Protection) followed by two numbers (i.e. IP65) where the numbers define the degree of protection. The first digit (Foreign Bodies Protection) indicates the extent of protection against particles entering the fixture and the second digit (Water Protection) indicates the extent of protection against water entering the fixture. An **IP65** rated lighting fixture is one, which has been designed and tested to protect against the ingress of dust **(6)** and low-pressure water jets from any direction **(5)**.

## UNPACKING

Every device has been thoroughly tested and has been shipped in perfect operating condition. Carefully check the shipping carton for damage that may have occurred during shipping. If the carton is damaged, carefully inspect the device for damage, and be sure all accessories necessary to install and operate the device have arrived intact. In the event damage has been found or parts are missing, please contact our customer support team for further instructions. Please do not return this device to your dealer without first contacting customer support. Please do not discard the shipping carton in the trash. Please recycle whenever possible.

## BOX CONTENTS

Omega Brackets (x2)  
IP65 Rated 5pin DMX Cable  
IP65 Rated RJ45 DATA Cable (Fixture to Fixture Interconnect Use Only!)  
IP65 Rated Twist-Lock Power Cable

## CUSTOMER SUPPORT

Contact ELATION Service for any product related service and support needs. Also visit [forums.elationlighting.com](http://forums.elationlighting.com) with questions, comments or suggestions.

**ELATION SERVICE USA - Monday - Friday 8:00am to 4:30pm PST**  
**323-582-3322 | Fax 323-832-9142 | [support@elationlighting.com](mailto:support@elationlighting.com)**

**ELATION SERVICE EUROPE - Monday - Friday 08:30 to 17:00 CET**  
**+31 45 546 85 63 | Fax +31 45 546 85 96 | [support@elationlighting.eu](mailto:support@elationlighting.eu)**

**REPLACEMENT PARTS** please visit [parts.elationlighting.com](http://parts.elationlighting.com)

# WARRANTY RETURNS (USA ONLY)

To obtain warranty service, a Return Materials Authorization (RMA) number must first be obtained from ELATION. It is the Customer's responsibility to provide product proof of purchase and serial number by acceptable evidence such as an invoice copy or an approved ELATION Extended Warranty Certificate ("EWC") and any relevant maintenance records at the time warranty service is sought. Failure to provide acceptable evidence of product proof of purchase or EWC and any relevant maintenance records may be cause for denial of warranty service.

Products returned for warranty service must be sent without any accessories (i.e., power, data, and safety cables, brackets, clamps, rigging hardware, frost filters, gel frames, barn doors, lens, hoses, nozzles, rack mounting hardware, etc.), must be boxed using the original and/or suitable packaging materials (double-box and foam) that provides ample product protection for ground and/or air freight transit, and must be shipped freight pre-paid and insured to ELATION in Los Angeles, CA or an ELATION Authorized Service Center. The RMA number must be clearly written on the outside of the return box, and a brief description of the problem and the RMA number must be documented and included in the box.

Products returned for warranty service without an RMA number clearly marked on the outside of the package will be refused and returned to the shipper at the Customer's expense. Products returned for warranty service, which are received damaged due to inadequate and/or improper packaging and/or due to damage caused by shipping carrier, may incur additional repair charges before warranty service begins and/or may void this warranty. If any product accessories (included and/or optional) are shipped with the product, ELATION and/or the ELATION Authorized Service Center shall have no liability what so ever for the loss and/or damage to any such accessories, nor the safe return thereof. If the requested warranty repairs or service (including parts replacement) are within the terms of this warranty, ELATION will pay return ground transportation shipping charges to a single designated point within the United States.

# SAFETY GUIDELINES

This fixture is a sophisticated piece of electronic equipment. To guarantee a smooth operation, it is important to follow all instructions and guidelines in this manual. Elation Professional is not responsible for injury and/or damages resulting from the misuse of this fixture due to the disregard of the information printed in this manual. Only qualified and/or certified personnel should perform installation of this fixture and only the original rigging parts (omega brackets) included with this fixture should be used for installation. Any modifications to the fixture and/or the included mounting hardware will void the original manufacturer's warranty and increase the risk of damage and/or personal injury.



**PROTECTION CLASS 1 - FIXTURE MUST BE PROPERLY GROUNDED.**



**THERE ARE NO USER SERVICEABLE PARTS INSIDE THIS UNIT. DO NOT ATTEMPT ANY REPAIRS YOURSELF; DOING SO WILL VOID YOUR MANUFACTURER'S WARRANTY. DAMAGES RESULTING FROM MODIFICATIONS TO THIS FIXTURE AND/OR THE DISREGARD OF SAFETY INSTRUCTIONS AND GUIDELINES IN THIS MANUAL VOID THE MANUFACTURE'S WARRANTY AND ARE NOT SUBJECT TO ANY WARRANTY CLAIMS AND/OR REPAIRS.**



**DO NOT PLUG FIXTURE INTO A DIMMER PACK!  
NEVER OPEN THIS FIXTURE WHILE IN USE!  
UNPLUG POWER BEFORE SERVICING FIXTURE!  
NEVER TOUCH FIXTURE DURING OPERATION, AS IT MAY BE HOT!  
KEEP FLAMMABLE MATERIALS AWAY FROM FIXTURE!**



**NEVER LOOK DIRECTLY INTO THE LIGHT SOURCE!  
RETINA INJURY RISK - MAY INDUCE BLINDNESS!  
SENSITIVE PERSONS MAY SUFFER AN EPILEPTIC SHOCK!**



**INDOOR / DRY LOCATIONS USE ONLY!  
DO NOT EXPOSE FIXTURE TO RAIN AND MOISTURE!**



**MINIMUM DISTANCE TO OBJECTS/SURFACES  
MUST BE 6.6 FEET (2 METERS)  
MAXIMUM TEMP OF EXTERNAL SURFACE 185° F (85°C)  
MINIMUM DISTANCE OF INFLAMMABLE MATERIALS  
FROM THE SURFACE 1.6 FEET (0.5 METER)**

# SAFETY GUIDELINES

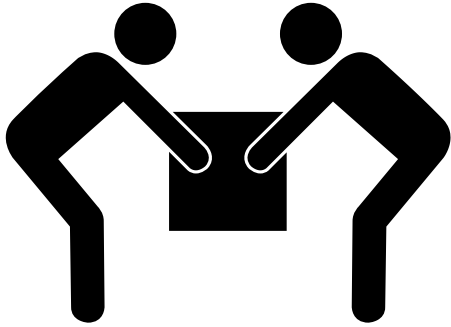

89.9 lbs. (40.8kg)

## WARNING

### TWO PERSON LIFT REQUIRED

## ! CAUTION

**HIGH  
INTENSITY  
ULTRAVIOLET  
LIGHT**



AVOID DIRECT EYE & SKIN EXPOSURE.  
WEAR PROPER EYE & SKIN PROTECTION.  
SEE MANUAL FOR SAFETY INSTRUCTIONS.

**RISK GROUP 3 - RISK OF EXPOSURE TO ULTRAVIOLET UV RADIATION! FIXTURE EMITS HIGH INTENSITY WAVELENGTH OF ULTRAVIOLET UV LIGHT FROM THE UV COLOR FILTER. WEAR PROPER EYE AND SKIN PROTECTION. AVOID PROLONGED PERIODS OF EXPOSURE TO UV COLOR FILTER. AVOID WEARING WHITE COLOR CLOTHING AND/OR USING UV PAINTS ON SKIN. AVOID DIRECT EYE AND/OR SKIN EXPOSURE AT DISTANCES LESS THAN 11 feet (3.3m). DO NOT OPERATE FIXTURE WITH DAMAGED/MISSING EXTERNAL COVERS. DO NOT LOOK DIRECTLY INTO THE UV LIGHT AND/OR VIEW UV LIGHT DIRECTLY WITH OPTICAL INSTRUMENTS THAT MAY CONCENTRATE THE LIGHT/RADIATION OUTPUT.**

**INDIVIDUALS SUFFERING FROM A RANGE OF EYE CONDITIONS, SUNLIGHT EXPOSURE DIS-ORDERS, OR INDIVIDUALS USING PHOTSENSITIVE MEDICATION, MAY RECEIVE DISCOMFORT IF EXPOSED TO THE ULTRAVIOLET UV LIGHT EMITTED FROM THE UV LED.**

**DO NOT TOUCH** the fixture housing during operation. Turn OFF the power and allow approximately 15 minutes for the fixture to cool down before serving.

**DO NOT** shake fixture, avoid brute force when installing and/or operating fixture.

**DO NOT** operate fixture if the power cord is frayed, crimped, damaged and/or if any of the power cord connectors are damaged and do not insert into the fixture securely with ease. NEVER force a power cord connector into the fixture. If the power cord or any of its connectors are damaged, replace it immediately with a new one of similar power rating.

**DO NOT** block any air ventilation slots.

All fan and air inlets must remain clean and never blocked.

Allow approx. 6" (15cm) between fixture and other devices or a wall for proper cooling.

Always disconnect fixture from main power source before performing any type of service and/or cleaning procedure. Only handle the power cord by the plug end, never pull out the plug by tugging the wire portion of the cord.

During the initial operation of this fixture, a light smoke or smell may emit from the interior of the fixture. This is a normal process and is caused by excess paint in the interior of the casing burning off from the heat associated with the lamp and will decrease gradually over time.

Consistent operational breaks will ensure fixture will function properly for many years.

**ONLY** use the original packaging and materials to transport the fixture in for service.

# MAINTENANCE GUIDELINES



**DISCONNECT POWER BEFORE PERFORMING ANY MAINTENANCE!**

## CLEANING

Frequent cleaning is recommended to insure proper function, optimized light output, and an extended life. The frequency of cleaning depends on the environment in which the fixture operates: damp, smoky or particularly dirty environments can cause greater accumulation of dirt on the fixture's optics. Clean the external lens surface at least every 20 days with a soft cloth to avoid dirt/debris accumulation.

**NEVER** use alcohol, solvents, or ammonia-based cleaners.

## MAINTENANCE

Regular inspections are recommended to insure proper function and extended life.

There are no user serviceable parts inside this fixture, please refer all other service issues to an authorized Elation service technician. Should you need any spare parts, please order genuine parts from an authorized Elation dealer.

Please refer to the following points during routine inspections:

A detailed electric check by an approved electrical engineer every three months, to make sure the circuit contacts are in good condition and prevent overheating.

Be sure all screws and fasteners are securely tightened at all times. Loose screws may fall out during normal operation resulting in damage or injury as larger parts could fall.

Check for any deformations on the housing, color lenses, rigging hardware and rigging points (ceiling, suspension, trussing). Deformations in the housing could allow for dust to enter into the fixture. Damaged rigging points or unsecured rigging could cause the fixture to fall and seriously injure a person(s).

Electric power supply cables must not show any damage, material fatigue or sediments.

**NEVER** remove the ground prong from the power cable.



# FIXTURE OVERVIEW

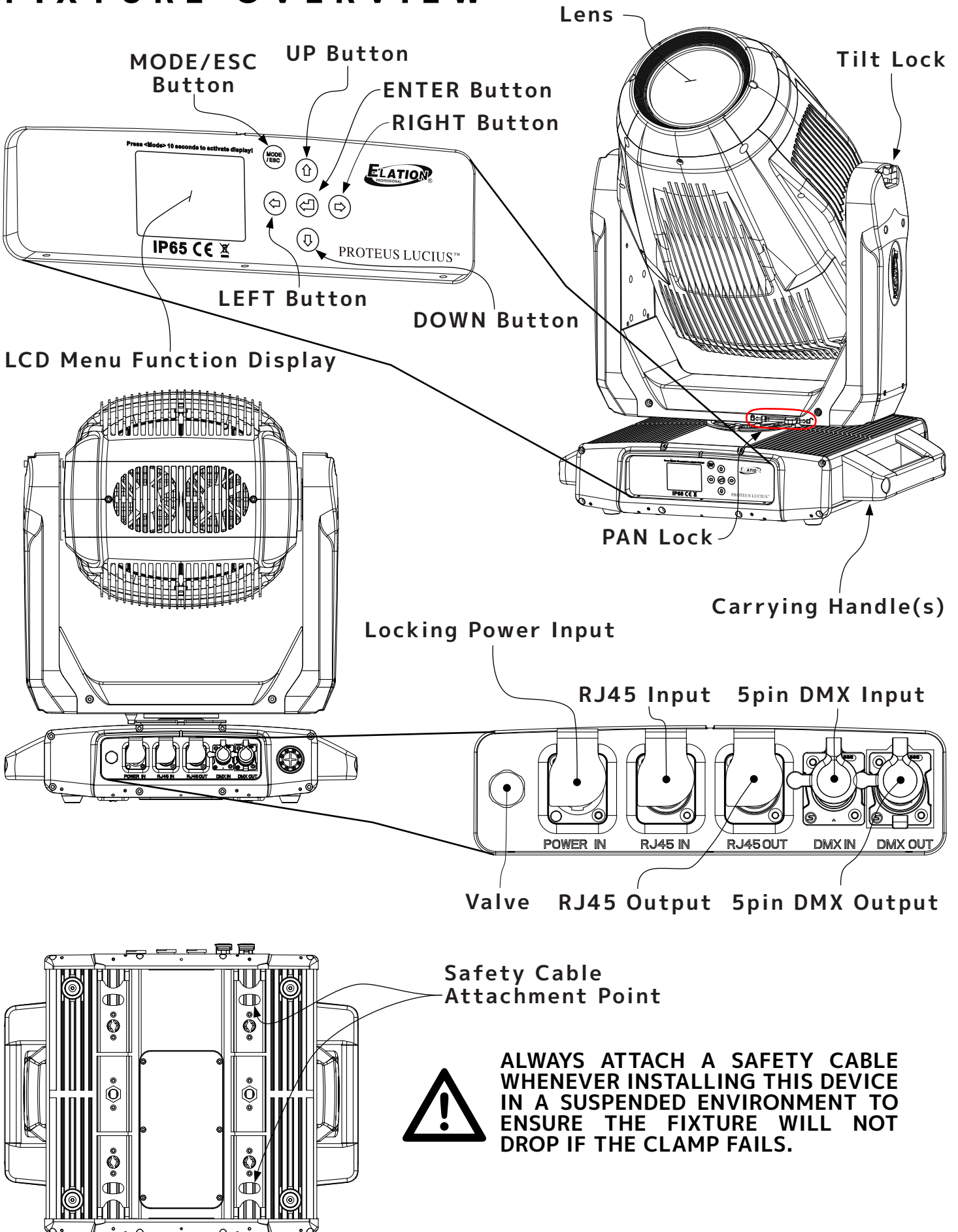

**ALWAYS ATTACH A SAFETY CABLE WHENEVER INSTALLING THIS DEVICE IN A SUSPENDED ENVIRONMENT TO ENSURE THE FIXTURE WILL NOT DROP IF THE CLAMP FAILS.**

# COLORS AND GOBOS

## COLOR FLAGS

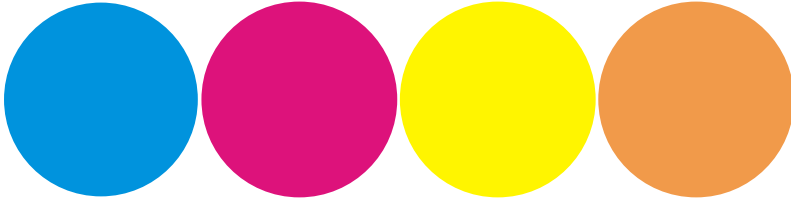

CYAN      MAGENTA      YELLOW      C.T.O.

## COLOR WHEEL

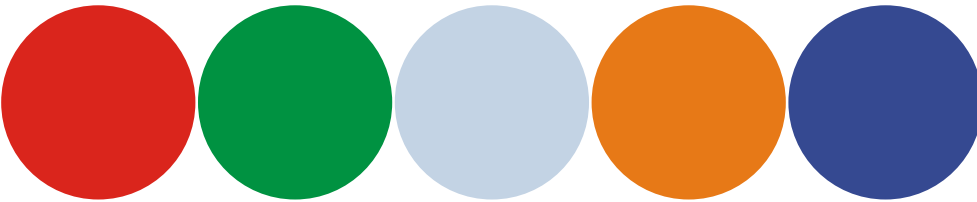

RED      GREEN      HIGH CRI      ORANGE      BLUE

## INTERCHANGEABLE – ROTATING GLASS GOBO WHEEL

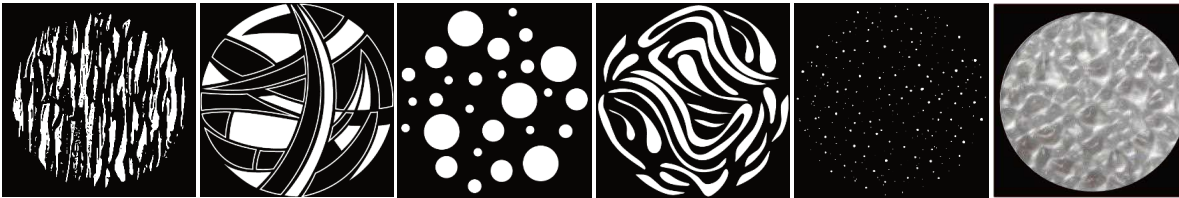

Pos. 1      Pos. 2      Pos. 3      Pos. 4      Pos. 5      Pos. 6

## INTERCHANGEABLE – ROTATING GLASS GOBO WHEEL



Pos. 1      Pos. 2      Pos. 3      Pos. 4      Pos. 5      Pos. 6      Pos. 7

## INTERCHANGEABLE STATIC – FIXED GLASS GOBO WHEEL

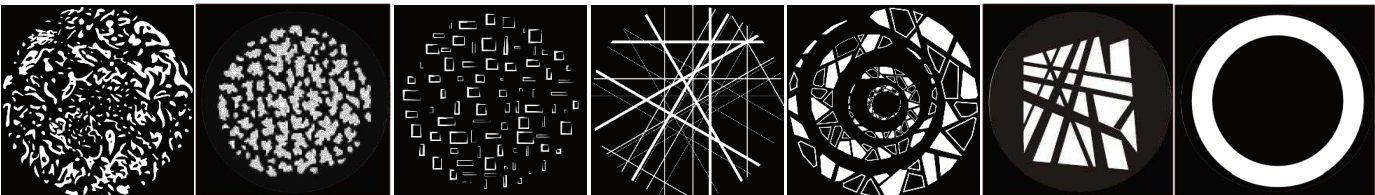

Pos. 1      Pos. 2      Pos. 3      Pos. 4      Pos. 5      Pos. 6      Pos. 7

## BI-DIRECTIONAL ANIMATION WHEEL

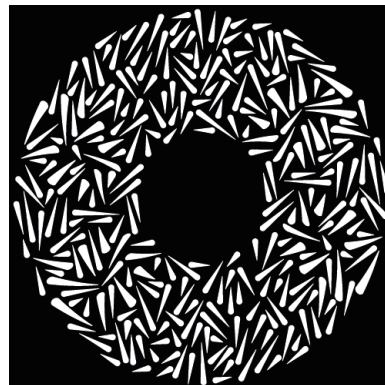

# CUSTOM GOBOS

ROTATING WHEEL1 GOBOS - Pos. 1-5:	
Gobo Holder Diameter	Ø34mm
Gobo O.D. (Max. Outer Diameter)	Ø33.8mm
Gobo I.D. (Max. Image Diameter)	Ø21mm
Gobo Thickness	1.1mm±0.1mm
Gobo Material	CORNING

ROTATING WHEEL1 GOBOS - Pos. 6:	
Gobo Holder Diameter	Ø34mm
Gobo O.D. (Max. Outer Diameter)	Ø34mm
Gobo I.D. (Max. Image Diameter)	Ø21mm
Gobo Thickness	2.5mm±0.1mm
Gobo Material	GLASS

## ROTATING WHEEL1 GOBOS

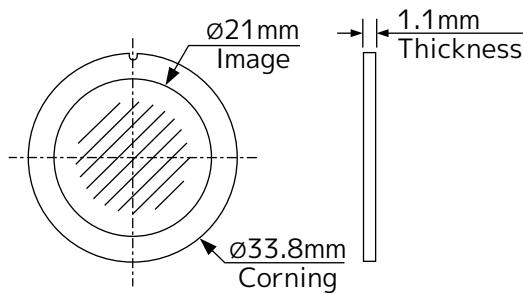

Pos. 1 - Pos. 5

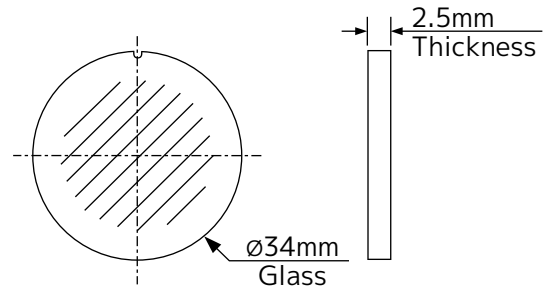

Pos. 6

## ROTATING WHEEL1 GOBO HOLDERS

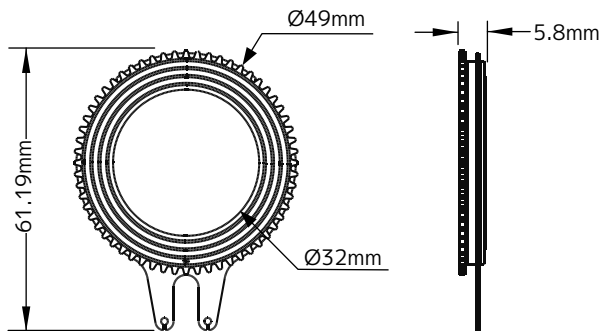

5.01.02.01.0685-0

Pos. 1 - Pos. 5

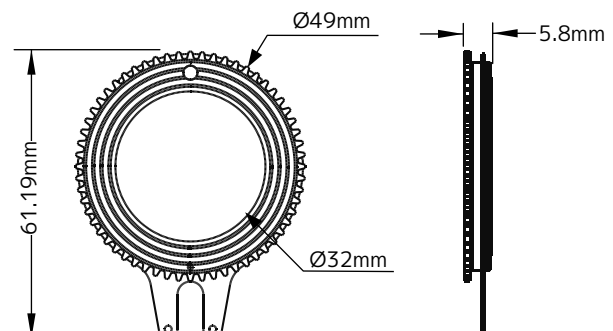

5.01.02.01.0599-0

Pos. 6

Proteus Lucius utilizes different size gobo holders on every wheel.

**Please be aware of the intended position and correct sizing requirements of custom gobos.**

**\*\*\* IMPORTANT NOTICE REGARDING CUSTOM GOBOS \*\*\***

Due to the high temperature optical system, special glass material is required for custom gobos. Due to varying manufacturing processes and tolerances, it is highly recommended to provide a gobo sample and holder from the fixture to the custom gobo vendor for accurate sizing. Extended testing of custom gobo designs is highly recommended prior to use. Contact ELATION SERVICE for further information.

ELATION SERVICE USA -Monday -Friday 8:00am to 4:30pm PST  
323-582-3322 | Fax 323-832-9142 | support@elationlighting.com

ELATION SERVICE EUROPE -Monday -Friday 08:30 to 17:00 CET  
+31 45 546 85 63 | Fax +31 45 54685 96 | support@elationlighting.eu

# CUSTOM GOBOS

ROTATING WHEEL2 GOBOS - Pos. 1-6:	
Gobo Holder Diameter	Ø27mm
Gobo O.D. (Max. Outer Diameter)	Ø26.8mm
Gobo I.D. (Max. Image Diameter)	Ø21mm
Gobo Thickness	1.1mm±0.1mm
Gobo Material	CORNING

ROTATING WHEEL2 GOBOS - Pos. 7:	
Gobo Holder Diameter	Ø27mm
Gobo O.D. (Max. Outer Diameter)	Ø26.8mm
Gobo I.D. (Max. Image Diameter)	Ø21mm
Gobo Thickness	2.5mm±0.1mm
Gobo Material	CORNING

## ROTATING WHEEL2 GOBOS

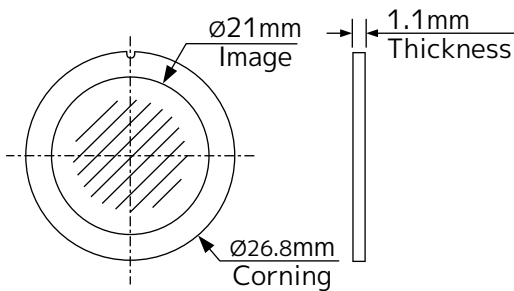

Pos. 1 - Pos. 6

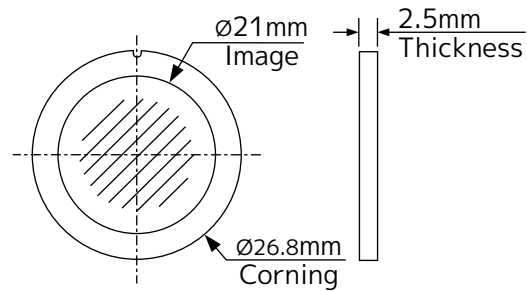

Pos. 7

## ROTATING WHEEL2 GOBO HOLDERS

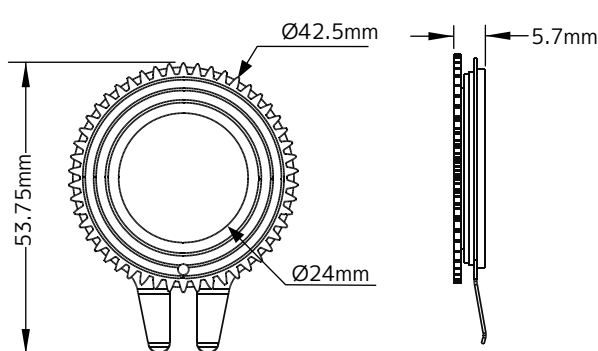

5.01.02.01.0684-0

Pos. 1 - Pos. 6

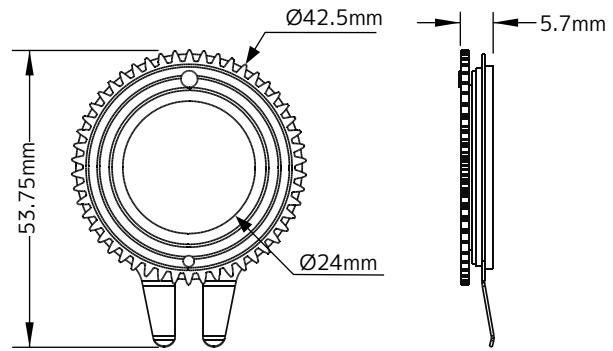

5.01.02.01.0598-0

Pos. 7

Proteus Lucius utilizes different size gobo holders on every wheel.

**Please be aware of the intended position and correct sizing requirements of custom gobos.**

**\*\*\* IMPORTANT NOTICE REGARDING CUSTOM GOBOS \*\*\***

Due to the high temperature optical system, special glass material is required for custom gobos. Due to varying manufacturing processes and tolerances, it is highly recommended to provide a gobo sample and holder from the fixture to the custom gobo vendor for accurate sizing. Extended testing of custom gobo designs is highly recommended prior to use. Contact ELATION SERVICE for further information.

ELATION SERVICE USA -Monday -Friday 8:00am to 4:30pm PST  
323-582-3322 | Fax 323-832-9142 | support@elationlighting.com

ELATION SERVICE EUROPE -Monday -Friday 08:30 to 17:00 CET  
+31 45 546 85 63 | Fax +31 45 54685 96 | support@elationlighting.eu

# CUSTOM GOBOS

FIXED WHEEL GOBOS:	
Gobo Holder Diameter	Ø30mm
Gobo O.D. (Max. Outer Diameter)	Ø29.8mm
Gobo I.D. (Max. Image Diameter)	Ø21mm
Gobo Thickness	1.1mm±0.1mm
Gobo Material	CORNING

## FIXED WHEEL GOBOS

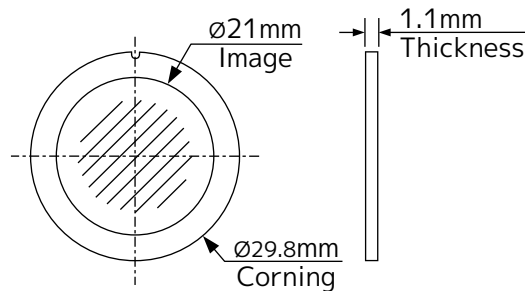

## FIXED WHEEL GOBO HOLDERS

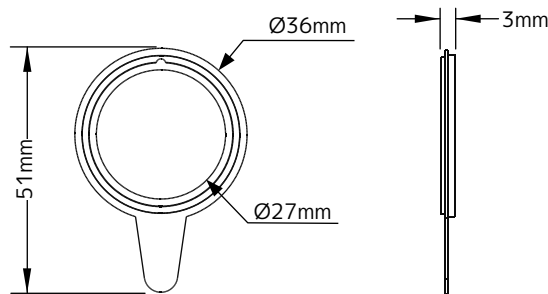

5.01.02.01.0694-0

Proteus Lucius utilizes different size gobo holders on every wheel.

**Please be aware of the intended position and correct sizing requirements of custom gobos.**

**\*\*\* IMPORTANT NOTICE REGARDING CUSTOM GOBOS \*\*\***

Due to the high temperature optical system, special glass material is required for custom gobos. Due to varying manufacturing processes and tolerances, it is highly recommended to provide a gobo sample and holder from the fixture to the custom gobo vendor for accurate sizing. Extended testing of custom gobo designs is highly recommended prior to use. Contact ELATION SERVICE for further information.

ELATION SERVICE USA -Monday -Friday 8:00am to 4:30pm PST  
323-582-3322 | Fax 323-832-9142 | support@elationlighting.com

ELATION SERVICE EUROPE -Monday -Friday 08:30 to 17:00 CET  
+31 45 546 85 63 | Fax +31 45 54685 96 | support@elationlighting.eu

# GOBO INSTALLATION

## REPLACING A ROTATING GOBO



Locate the specific Rotating GOBO to replace. Carefully grip the GOBO using your thumb and index finger, gently lift it slightly, and then pull it out and away until it fully clears the GOBO Wheel.



Locate the tab of the spring, and with a precision pick (or similar tool), carefully press the retaining spring inward to relieve the tension. Remove the retaining spring and carefully separate the GOBO from the GOBO Holder. Lastly, remove the flat washer attached to the removed GOBO and attach it to the desired replacement GOBO. Install the replacement Rotating GOBO following the steps above in reverse order.

**CAUTION: TAKE CARE NOT TO SCRATCH GOBO OR GOBO HOLDER**

## REPLACING A STATIC GOBO



Rotate the Static GOBO Wheel until the desired GOBO is visible through the OPEN slot in the Rotating GOBO Wheel. Using a precision pick (or similar tool), carefully press the Static GOBO Holder down slightly, then using your thumb and index finger, gently pull it out and away until it fully clears the GOBO Wheel.

Locate the tab of the retaining spring. Using a precision pick (or similar tool), carefully press the retaining spring inward to relieve the tension. Remove the retaining spring and carefully separate the GOBO from the GOBO Holder. Lastly, remove the flat washer attached to the removed GOBO and attach it to the desired replacement GOBO. Install the replacement Static GOBO following the steps above in reverse

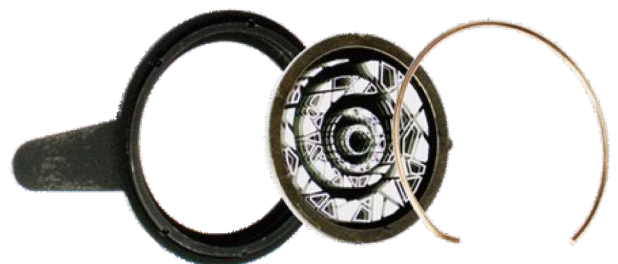

# TORQUE SETTINGS FOR SCREWS



The hex-head screws holding either the panels or the base **MUST** be tightened with a torque wrench (not included). **TORQUE SETTING = 11 lbf-in. (12.7kgf-cm)\***

**\* lbf-in = Pound Force Inches | kgf-cm = Kilogram Force Centimeters**



**CAUTION! DO NOT OVER TORQUE SCREWS AS THIS CAN CAUSE LEAKAGE ISSUES! TO CONFIRM THE IP65 INTEGRITY AFTER A LAMP REPLACEMENT, TEST FIXTURE USING THE ELATION IP TESTER. CONTACT ELATION SERVICE FOR MORE DETAILS.**



# INSTALLATION GUIDELINES



## FLAMMABLE MATERIAL WARNING

Keep fixture minimum 5.0 feet (1.5m) away from flammable materials and/or pyrotechnics.



## ELECTRICAL CONNECTIONS

A qualified electrician should be used for all electrical connections and/or installations.



**USE CAUTION WHEN POWER LINKING OTHER MODEL FIXTURES AS THE POWER CONSUMPTION OF OTHER MODEL FIXTURES MAY EXCEED THE MAX POWER OUTPUT ON THIS FIXTURE. CHECK SILK SCREEN FOR MAX AMPS.**



**MINIMUM DISTANCE TO OBJECTS/SURFACES  
MUST BE 1.6 FOOT (0.5 METERS)**



**MINIMUM DISTANCE OF INFLAMMABLE MATERIALS  
FROM THE SURFACE 1.6 FEET (0.5 METER)**



**MAXIMUM AMBIENT TEMPERATURE 194° F (90°C)**



**DO NOT INSTALL THE FIXTURE IF YOU ARE NOT QUALIFIED TO DO SO!**

Fixture **MUST** be installed following all local, national, and country commercial electrical and construction codes and regulations.

Before rigging/mounting the fixture to any metal truss/structure or placing the fixture on any surface, a professional equipment installer **MUST** be consulted to determine if the metal truss/structure or surface is properly certified to safely hold the combined weight of the fixture, clamps, cables, and accessories.

Overhead rigging requires extensive experience, including, amongst others, calculating working load limits, installation material being used, and periodic safety inspection of all installation material and the fixture. If you lack these qualifications, do not attempt the installation yourself. Improper installation can result in bodily injury.

Fixture ambient operating temperature range is **14° to 113°F. (-10° to 45°C)**

Do not use the fixture under or above this temperature.

Fixture should be installed in areas outside walking paths, seating areas, or away from areas where unauthorized personnel might reach the fixture by hand.

**NEVER** stand directly below the fixture when rigging, removing or servicing.

Overhead fixture installation must always be secured with a secondary safety attachment, such as an appropriately rated safety cable.

Allow approximately 10 minutes for the fixture to cool down before serving.



# INSTALLATION GUIDELINES

## OMEGA BRACKETS WITH CLAMP INSTALLATION

Insert the Omega Brackets into the matching holes on the bottom of the fixture. Secure the Omega Brackets to the fixture by turning each quick-lock fastener ¼ turn clockwise; making sure the fastener is completely locked. Omega Brackets can be installed into the fixture base as illustrated below.

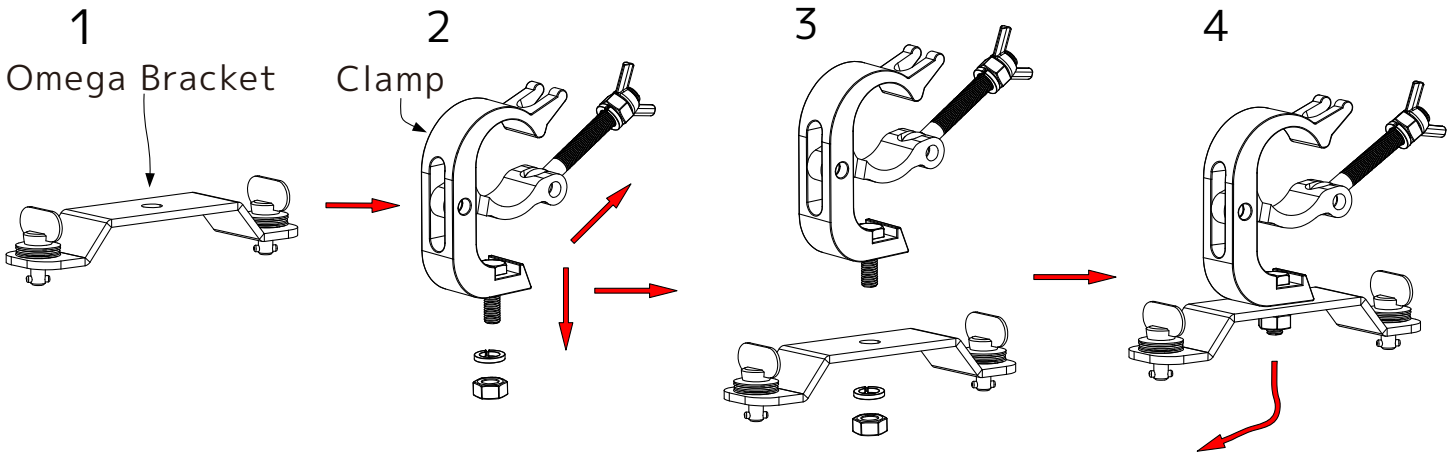

## SAFETY CABLE

**ALWAYS ATTACH AN APPROPRIATELY RATED SAFETY CABLE WHENEVER INSTALLING THIS FIXTURE IN A SUSPENDED ENVIRONMENT TO ENSURE THE FIXTURE WILL NOT FALL IF THE CLAMP FAILS.**

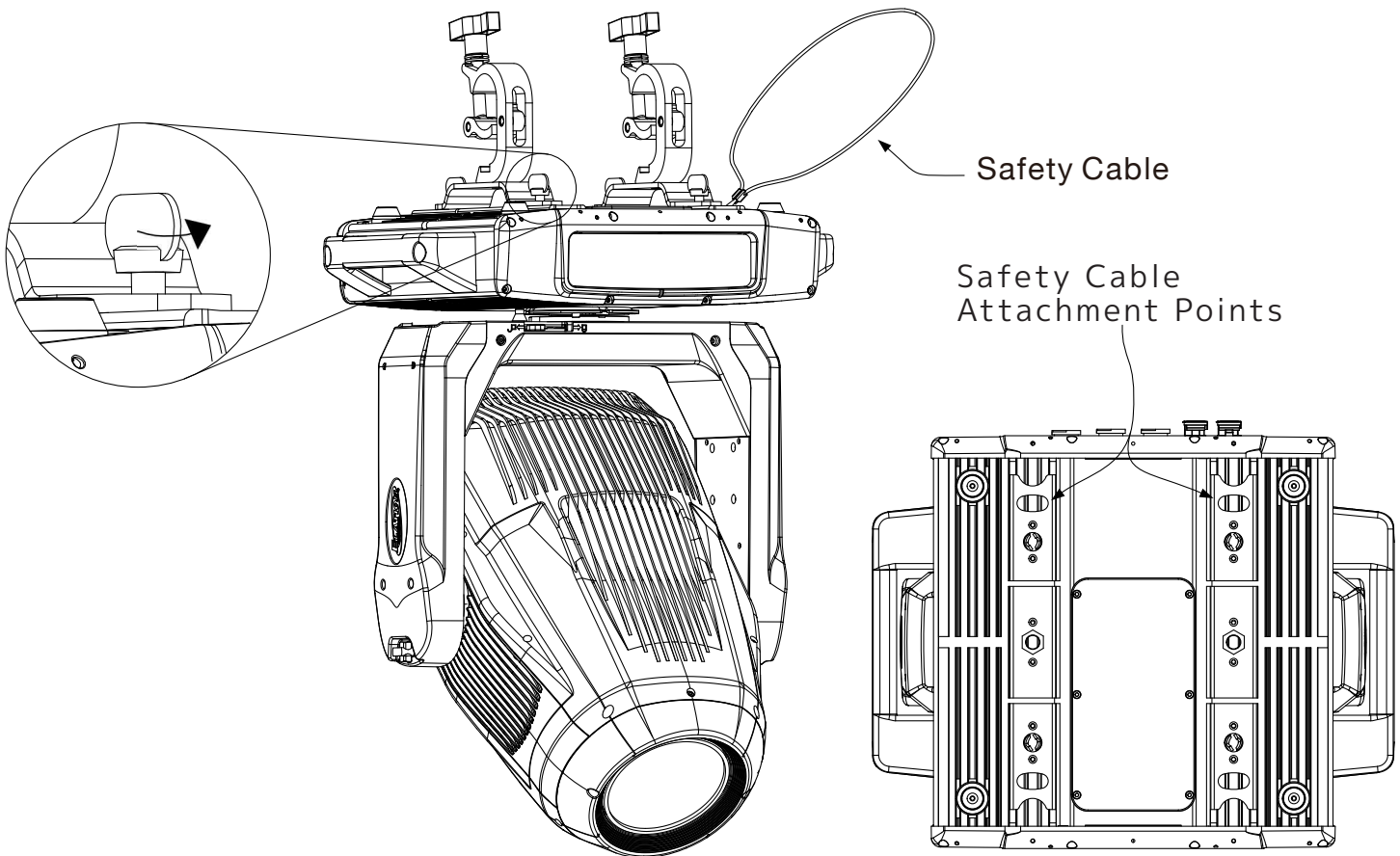

## MOUNTING THE FIXTURE ON A TRUSS USING CLAMPS WITH OMEGA BRACKETS

When mounting the fixture to a truss, be sure to secure an appropriately rated professional grade rigging clamp to the included **Omega Brackets** using an M10 screw fitted through the center hole of the **Omega Brackets**. The fixture provides built-in rigging points for a **SAFETY CABLE** (not included). Be sure to only use one of the designated rigging points for the safety cable and never secure a safety cable to a carrying handle.

# INSTALLATION GUIDELINES

## CLAMP INSTALLATION

Insert (2x) minimum grade 8.8 steel M12x19mm bolts (not included) through the respective mounting hole of the clamp (not included), and then thread it into the matching 12M holes on the bottom of the fixture base. Both bolts must be threaded at least 20-30mm (0.8 - 1.2ins) into the fixture base.

(2x) M12 Threaded Holes

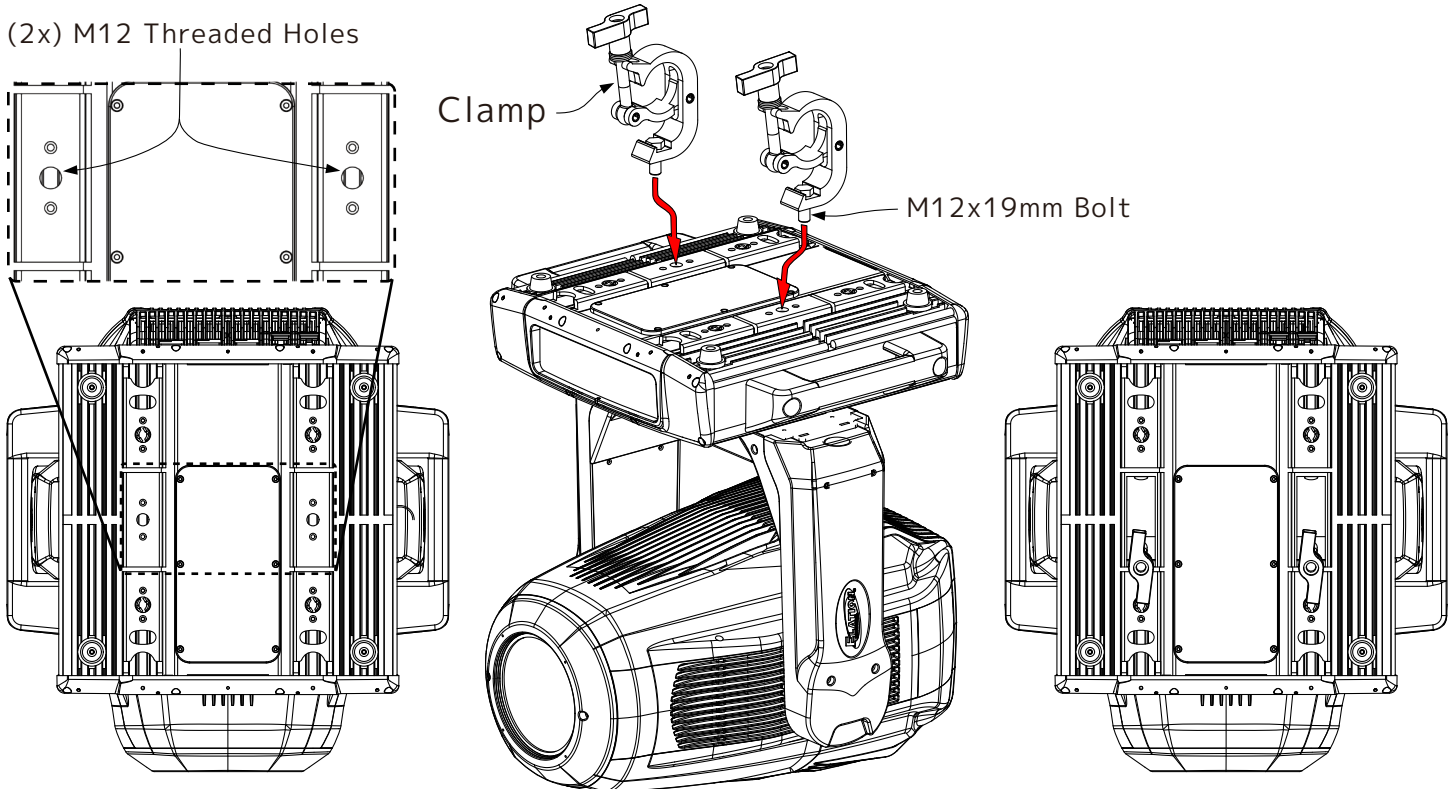

Route Safety Cable through Safety Cable Attachment Points and around truss

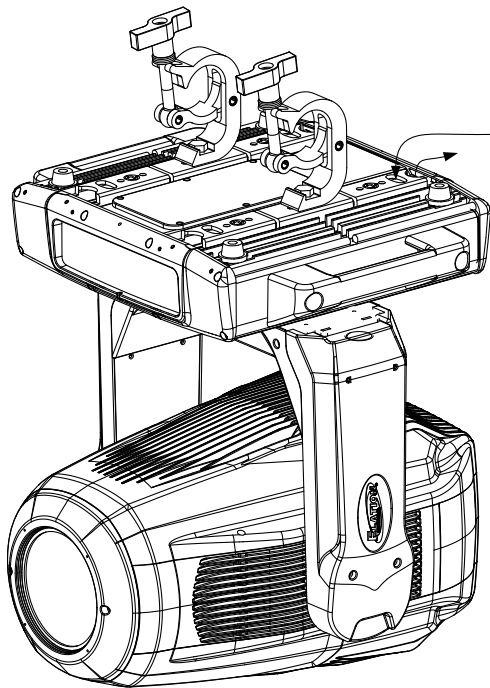

**SAFETY CABLE**  
ALWAYS ATTACH AN APPROPRIATELY RATED SAFETY CABLE WHENEVER INSTALLING THIS FIXTURE IN A SUSPENDED ENVIRONMENT TO ENSURE THE FIXTURE WILL NOT FALL IF THE CLAMP FAILS.

## MOUNTING THE FIXTURE ON A TRUSS USING CLAMPS

When mounting the fixture to a truss, be sure to secure an appropriately rated professional grade rigging clamp to the bottom of the fixture using (2x) minimum grade 8.8 steel (2x) M12x19mm bolts fitted through the mounting hole of the Clamp. The fixture provides built-in rigging points for a SAFETY CABLE (not included). Be sure to only use one of the designated rigging points for the safety cable and never secure a safety cable to a carrying handle.

# INSTALLATION GUIDELINES

## RIGGING

Overhead rigging requires extensive experience, including among others calculating working load limits, installation material being used, and periodic safety inspection of all installation material and the fixture. If you lack these qualifications, do not attempt the installation yourself. Improper installation can result in bodily injury.

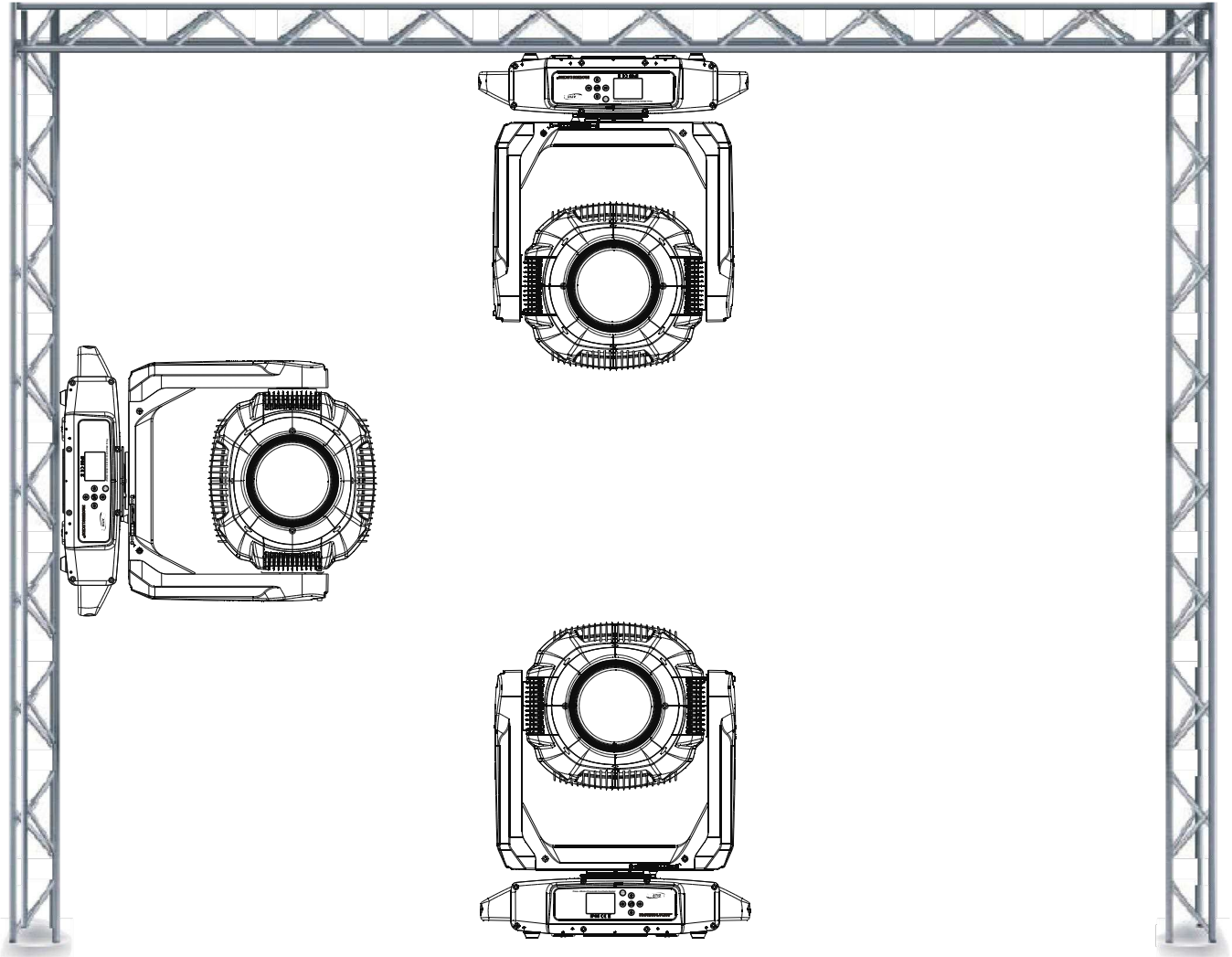

# INSTALLATION GUIDELINES

## ART-NET | sACN CONNECTION

When connecting fixture to a network switch to control multiple devices, a **Gigabit Ethernet Switch** that supports **IGMP (Internet Group Management Protocol)** is required. Using a **Gigabit Ethernet Switch** that does not support **IGMP** can cause erratic behavior of all connected devices to the switch. Click link below for more information about IGMP.

[https://en.wikipedia.org/wiki/Internet\\_Group\\_Management\\_Protocol](https://en.wikipedia.org/wiki/Internet_Group_Management_Protocol)

## POWER AND DATA CABLES



**TO MAINTAIN THE IP65 RATING INTEGRITY OF THE FIXTURE, ALL CABLES MUST BE RUN TOWARDS THE GROUND TO PREVENT WATER ACCUMULATION AROUND THE CONNECTIONS.**

### SYSTEM MENU LCD DISPLAY

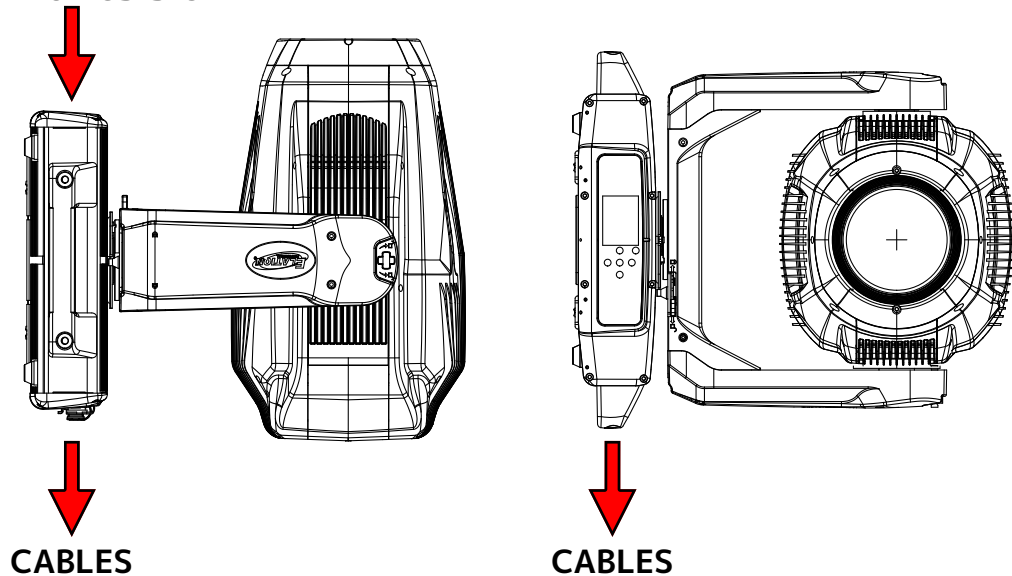

## INCLUDED RJ45 DATA CABLE



**THE INCLUDED RJ45 DATA CABLE IS FOR FIXTURE TO FIXTURE INTERCONNECTION ONLY! THE RJ45 CABLE CONNECTORS MAY NOT BE COMPATIBLE WITH OTHER RJ45/ETHERCON TYPE CONNECTORS.**

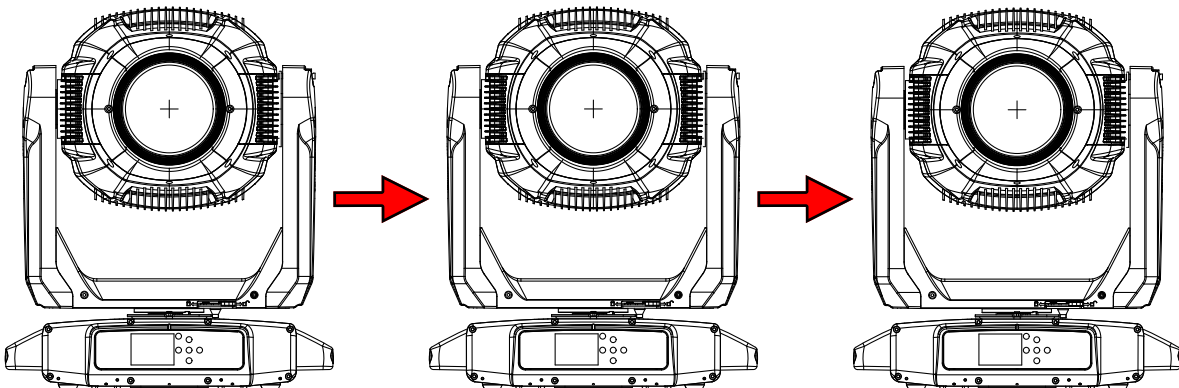

# INSTALLATION GUIDELINES

## POWER AND DATA CABLES



ENSURE ALL CONNECTIONS AND ENDCAPS ARE PROPERLY SEALED WITH DIELECTRIC GREASE (AVAILABLE AT MOST ELECTRICAL SUPPLIERS) TO PREVENT WATER CORROSION AND/OR ELECTRICAL SHORT CIRCUIT.



TO MAINTAIN THE IP65 RATING INTEGRITY OF THE FIXTURE AND PREVENT WATER FROM ENTERING THE FIXTURE, SEAL ALL UNUSED CONNECTION RUBBER CAPS.

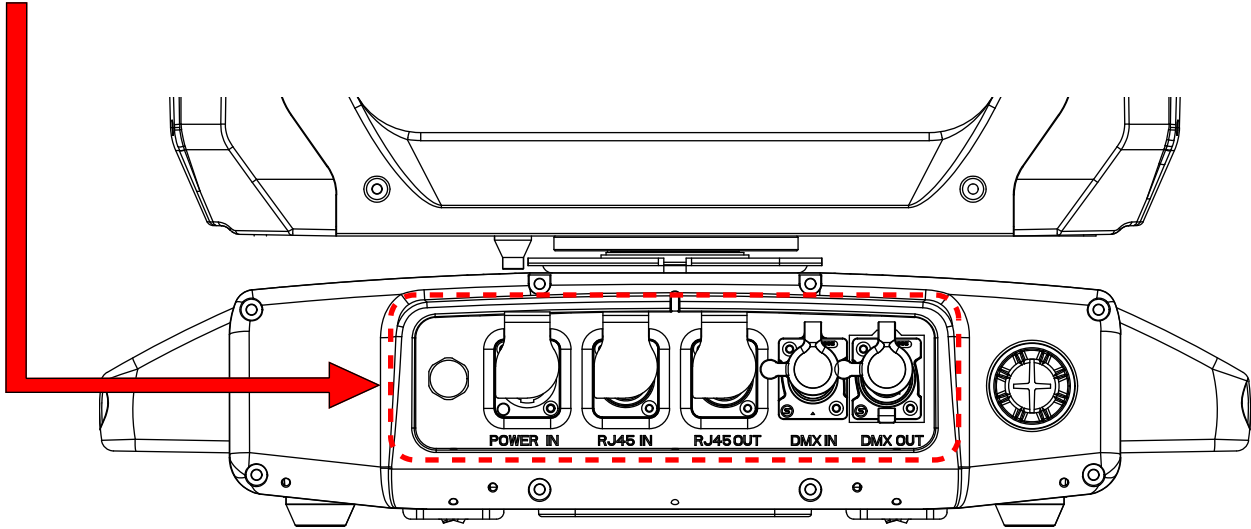

# INSTALLATION GUIDELINES

## POTENTIAL INTERNAL FIXTURE DAMAGE FROM EXTERNAL SOURCES OF LIGHT BEAMS

External sources of light beams from direct sunlight, lighting moving head fixtures, and lasers, which are focused directly towards the exterior housing and/or penetrate the front lens opening of ELATION lighting fixtures, can cause severe internal damage including burning to optics, dichroic color filters, glass and metal gobos, prisms, animation wheels, frost filters, iris, shutters, motors, belts, wiring, discharge lamps, and LEDs.

This issue is not specific only to ELATION lighting fixtures, it is a common issue with lighting fixtures from all manufacturers. Although there is no true way to fully prevent this issue from happening, the guidelines below can prevent any potential damage from occurring if followed. Contact ELATION Service for more details.

**DO NOT EXPOSE THE FIXTURE AND/OR FRONT LENS OPENING TO LIGHT BEAMS FROM DIRECT SUNLIGHT, OTHER LIGHTING MOVING HEAD FIXTURES, AND LASERS WHILE UNPACKING, INSTALLATION, USE, AND EXTENDED IDLE TIMES OUTDOORS. DO NOT FOCUS A LIGHT BEAM FROM ONE LIGHTING FIXTURE DIRECTLY TOWARDS ANOTHER.**

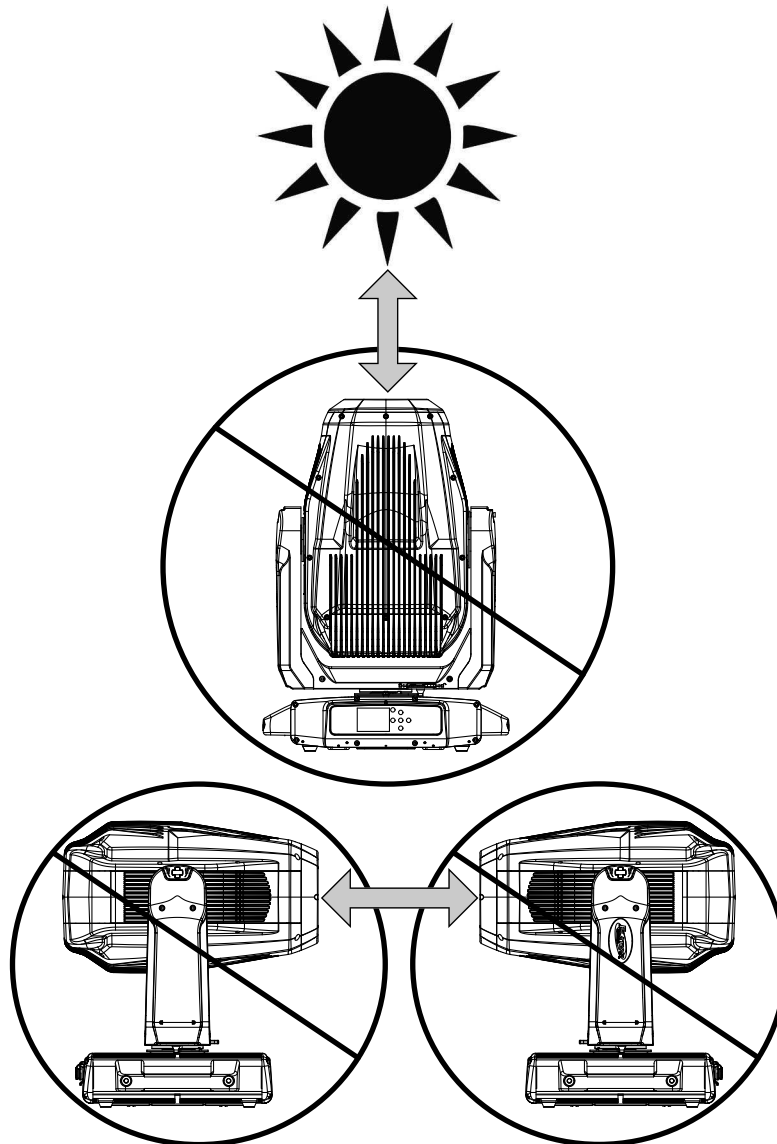

# SYSTEM MENU

The fixture includes an easy to navigate system menu. The control panel (see image below) located on the front of the fixture, provides access to the main system menu and is where all necessary system adjustments are made to the fixture. During normal operation, pressing **MODE/ESC** button once will access the fixture's main menu. Once in the main menu you can navigate through the different functions and access the sub-menus with the **UP**, **DOWN**, **RIGHT**, and **LEFT** buttons. Once you reach a field that requires adjusting, press the **ENTER** button to activate that field and use the **UP** and **DOWN** buttons to adjust the field. Pressing the **ENTER** button once more will confirm your setting. You may exit the main menu at any time without making any adjustments by pressing the **MODE/ESC** button.

NOTE: To access the LCD Menu Control Display via the internal battery, press and hold the **MODE/ESC** button for 10 seconds. The LCD Menu Control Display will shut **OFF** automatically about 1 minute from the last button press.

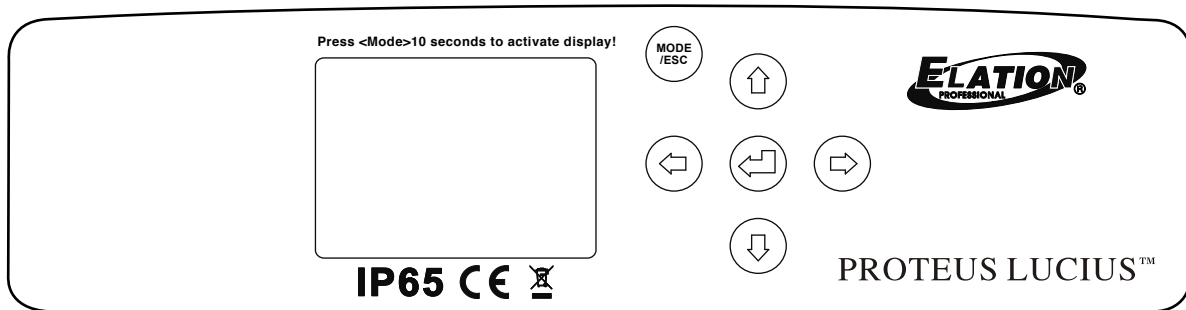

# SYSTEM MENU

ELATION PROTEUS LUCIUS				
Supports Software Versions: ≥ 1.3.0				
MAIN MENU	OPTIONS / VALUES (Default Settings in <b>BOLD</b> )			DESCRIPTION
<b>Function</b>	Set Dmx Address	A001~AXXX		DMX Address Setting
	Dmx Value	PAN.....		DMX Value Display
	Secondary Mode	Secondary1, Secondary2, Secondary3		Secondary Setting
	Auto Program	Primary / Alone		Auto Program
<b>Information</b>	Time Information	Current Time	XXXX(Hours)	Power On Running Time
		Total Run Time	XXXX(Hours)	Fixture Running Time
		Last Run Time	XXXX(Hours)	Fixture Last Times Clear
		LastRun Password	Password=XXX	Timer Password 038
		Clear Last Run	ON/OFF	Clear Fixture Last Time
	Temperature Info	LED Temperature	XXX°C/°F	Temperature in LED
		Base Temperature	XXX°C/°F	Temperature in Base
		Head Temperature	XXX°C/°F	Temperature in Fixture
	Humidity Info	Base Humidity	XXX%	Humidity in Base
		Head Humidity	XXX%	Humidity in Fixture
	Ethernet IP	Ethernet IP XXX. XXX. XXX. XXX XXX. XXX. XXX. XXX		Ethernet IP
	Fan Info	HeadFan1: xxxx RPM .....		Fan information
	Software Version	1U01: Vx.x.x 2U01: Vx.x.x :		Software Version
	Error Info	Error Record 1 Error Record 2 ... .. Error Record 10		PAN ..... PAN ..... ... .. PAN .....
<b>Personality</b>	Status Settings	Address Via DMX	ON/OFF	Address Via DMX
		No DMX Status	Close/ <b>Hold</b> /Auto	Auto Run If No DMX
		Pan Reverse	ON/OFF	Pan Reverse movement
		Tilt Reverse	ON/OFF	Tilt Reverse movement
		Pan Degree	360/ <b>540</b>	Pan Degree Select
		Feedback	ON/OFF	Movement Feedback
		Movement Speed	<b>Normal</b> /Slow	Movement Speed
		P/T Brake Mode	<b>Smooth</b> /Fast	P/T Brake Mode
		Hibernation	OFF, 01M~99M, <b>15M</b>	Standby Mode
	Service Setting	Password	Password=XXX	Password"=050"
		Clear Err. Info	ON/OFF	Clear Err. Info
	Fans Control	<b>Auto</b> / High/ Low/ Studio/ Mute		Fans Control
	Display Setting	Shutoff Time	02~60m <b>05m</b>	Display Shut Off Time
		Display Reverse	OFF/ON/ <b>AUTO</b>	Reverse 180 degree
Key Lock		ON/OFF	LCD Control Panel Key Lock	



MAIN MENU	OPTIONS / VALUES (Default Settings in <b>BOLD</b> )		DESCRIPTION	
Personality	Temperature C/F	Celsius <b>Fahren</b>	Temp C/F	
	Initial Status	PAN =XXX .....	Initial effect position	
	Select Signal	<b>DMX Only</b>	Select Signal	
		Art-Net sACN		
	Ethernet IP	XXX. XXX. XXX. XXX	Ethernet IP	
	Ether Mask IP	XXX. XXX. XXX. XXX	Ether Mask IP	
	Set Universe	000~32767	Setting Art-Net Universe	
	Dimmer Mode	<b>Standard</b>	Dimmer Mode	
		Stage		
		TV		
Architectural				
Theatre				
Refresh	Stage2 Delay 0s, 0.1s, 0.2s ... 10s	Refresh Frequency Rate Setting		
	<b>1200</b> , 900-1500,, 2500, 4000, 5000, 6000, 10000, 15000, 20000, 25000(Hz)			
DimmerCurve	<b>Linear</b> , Square, Inverse Square, S-Curve	DimmerCurve Setting		
ResetDef	<b>ON</b>	PassCode		
	OFF			
Reset Function	Reset All		Reset Function	
	Reset Pan&Tilt			
	Reset Colors			
	Reset Gobos			
	ResetZoomModules			
	Reset Others			
Effect Adjust	Test Channel		Test function	
	Manual Control	PAN =XXX :	Fine adjustment of the lamp	
	Calibration	Calibrate Password Pan=XXX :	Password "050" Calibrate and adjust the effects to standard/right position	
User Mode Set	User Mode	<b>Standard Mode</b> Extended Mode	User's mode to change channel numbers	
Edit Program	Select Program	Auto Pro Part 1 = Program 1 ~ 10 Program 1	Select Programs To Be Run	
		Auto Pro Part 2 = Program 1 ~ 10 Program 1		
		Auto Pro Part 3 = Program 1 ~ 10 Program 1		
	Edit Program	Prog 1 : Prog 10	ProgTest	Testing Program
			Step 01 = SCxxx Step 64 = SCxxx	Program In Loop Save and Exit
Edit Scenes	Scene 001 ~ Scene 250	Pan,Tilt,..... - Fade Time - - Scene Time - Input By Out	Save and Automatically Return Manual Scenes Edit	
Rec. Controller	XX~XX		Automatic Scenes Recorder	

# SYSTEM MENU

## FUNCTION - Auto Program

Define fixture mode (Primary or Alone) for running Auto Programs. Select desired internal programs under "Select Program", set the number of steps under "Edit program", and edit individual scenes under "Edit Scenes".

## PERSONALITY - Status Settings - Address Via DMX

When ON, define the desired DMX address via an external controller.

NOTE: This process assumes the fixture DMX address is set to 001. If fixture DMX address is not at 001, you must adjust the channel numbers accordingly in order for this feature to work. For example: if your fixture address is 010, then Channel 1 becomes Channel 10, Channel 2 becomes Channel 11, and Channel 3 becomes Channel 12.

1. Connect the fixture to the external controller and power ON.
2. Set the DMX value of Channel 1 on the controller to (7).
3. Set the DMX value of Channel 2 on the controller to (7) or (8).

When set to (7), the DMX address can be set between (1) and (255).

When set to (8), the DMX address can be set between (256) and (511).

4. Using Channel 3 on the controller set the desired DMX address of the fixture.

Example 1:

If the desired DMX address is 57, set Channel 1 to a value of (7), set Channel 2 to a value of (7), and then set Channel 3 to a value of (57).

Example 2:

If the desired DMX address is 420, set Channel 1 to a value of (7), set Channel 2 to a value of (8), and then set Channel 3 to a value of (164). (256+164=420)

5. After setting Channel 3 to the desired DMX address value, wait approximately 20 seconds for the fixture to complete the address reset function.

## PERSONALITY - Status Settings - Movement Speed

Select Movement Speed (Normal, Slow).

NOTE: For hanging position only use slow speed

## PERSONALITY - Service Settings - Password (050)

NOTE: The Service Password MUST be entered in order to access the following menus:  
Clear Err. Info .

## PERSONALITY - Display Setting - Key Lock

When ON, Control Panel buttons lock automatically after exiting main menu for 15 seconds. To unlock, keep MODE/ESC button pressed for 3 seconds.

## PERSONALITY - Dimmer Curve

Select dimming curve (Linear, Square, InverseSquare, S-Curve).

## PERSONALITY - Reset Default (011)

# SYSTEM MENU



**ONLY QUALIFIED TECHNICIANS SHOULD PERFORM THIS FUNCTION!**  
**NOTE: SAVED WHITE BALANCE IS ERASED AFTER A RESET IS PERFORMED!**

This function restores all fixture settings to the factory default settings. The password is 011 and must be entered each time a reset is performed.

## **EFFECT ADJUST - Test Channel**

Auto test each individual channel function independently from the DMX control board.

## **EFFECT ADJUST - Manual Control**

Select and manually test and fine adjust each individual channel function independently from DMX control board. This function will center PAN and TILT motors and set dimmer to 100%. PAN and TILT functions will still operate if the fixture needs to be positioned to a flat clear surface. With the individual functions, you can focus the light on a flat surface (wall) and perform fine adjustments.



## **EFFECT ADJUST - Calibration**

**ONLY QUALIFIED TECHNICIANS SHOULD PERFORM THIS FUNCTION.**

This function allows small adjustments to be made to the Pan, Tilt, and Zoom movements to compensate for wear or in the event a sensor has been knocked slightly out of place. Because improper use of this function can result in undesired operation this function has been password protected. The password is 050 and must be entered each time the calibration menu function is entered. Because calibration is an extremely delicate procedure, instructions on performing this action are left out of this manual. For a first-time calibrator, please contact our customer support team for step-by-step instructions.

## **EDIT PROGRAM - Rec. Controller**

The fixture features an integrated DMX-recorder by which you can transmit the programmed scenes from your DMX-controller to the moving head. Adjust the desired scene numbers via the encoder (from – to). When you call up the scenes at your controller, they will automatically be transmitted to the moving head.

# SYSTEM MENU

## EDIT PROGRAM - Record Controller - Working With Built - In Programs

A Primary unit can send up to 3 different data groups to the Secondary units, i.e. a Primary unit can start 3 different Secondary units, which run 3 different programs. The Primary unit sends the 3 program parts in a continuous loop.

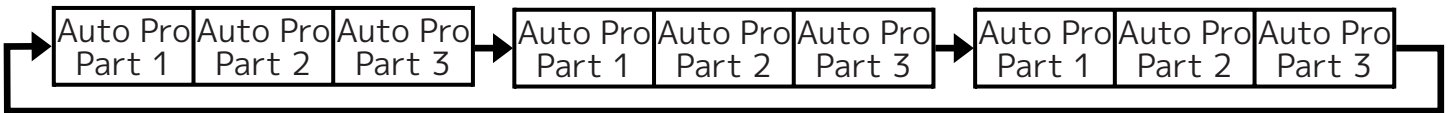

The Secondary unit receives data from the Primary unit according to the group which the Secondary unit was assigned to. If e.g. a Secondary unit is set to "Secondary 1" in the menu "Set to Secondary", the Primary unit sends "Auto Program Part 1" to the Secondary unit. If set to "Secondary 2", the Secondary unit receives "Auto Program Part 2".

To start an Auto Program proceed as follows:

1. Secondary Setting
  - Select "Function Mode".
  - Press ENTER to confirm.
  - Select "Set to Secondary".
  - Press ENTER to confirm.
  - Select "Secondary 1", "Secondary 2" or "Secondary 3".
  - Press ENTER to confirm.
  - Press MODE/ESC in order to return to the main menu.
2. Automatic Program Run
  - Select "Function Mode".
  - Press ENTER to confirm.
  - Select "Auto Program".
  - Press ENTER to confirm.
  - Select "Primary" or "Alone".
  - Press ENTER to confirm.
  - Press MODE/ESC in order to return to the main menu.

# SYSTEM MENU

## **EDIT PROGRAM - Record Controller - Working With Built-In Program [continued]**

3. Program Selection for Auto Pro Part
  - Select "Edit Program".
  - Press ENTER to confirm.
  - Select "Select Programs".
  - Press ENTER to confirm.
  - Select "Auto Pro Part 1", "Auto Pro Part 2" or "Auto Pro Part 3", and select which Secondary program is to be sent. Selection "Part 1" means, that the Secondary unit runs the same program as the Primary units.
  - Press ENTER to confirm.
  - Press MODE/ESC in order to return to the main menu.
4. Program Selection for Edit Program
  - Select "Edit Program".
  - Press ENTER to confirm.
  - Select "Edit Program".
  - Press ENTER to confirm.
  - Select the desired program to edit specific scenes into a specific program.
  - Press ENTER to confirm.
  - Press MODE/ESC in order to return to the main menu.
5. Automatic Scene Recording
  - Select "Edit Program".
  - Press ENTER to confirm.
  - Select "Edit Scenes".
  - Press ENTER to confirm.
  - Select desired scene numbers. A maximum of 250 scenes can be programmed.
  - Press ENTER to confirm.
  - Press MODE/ESC in order to return to the main menu.

## **EDIT PROGRAM - Record Controller - Working With Built - In Program [continued]**

Example:

Program 2 includes scenes: 10, 11, 12, & 13

Program 4 includes scenes: 8, 9, & 10

Program 6 includes scenes: 12, 13, 14, & 15

Auto Pro Part 1 is Program 2

Auto Pro Part 2 is Program 3

Auto Pro Part 3 is Program 6

The 3 Secondary groups run the Auto Program in certain time segments.

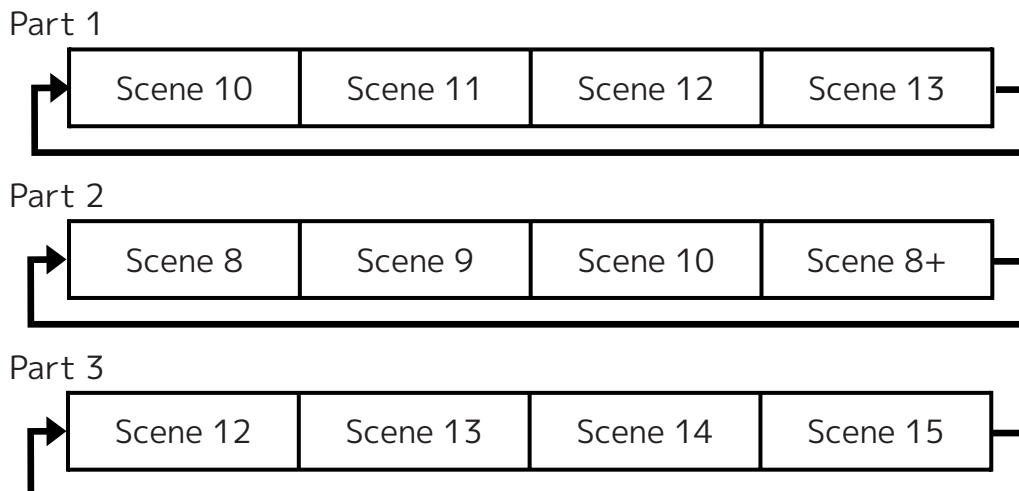

# DIMMER MODE

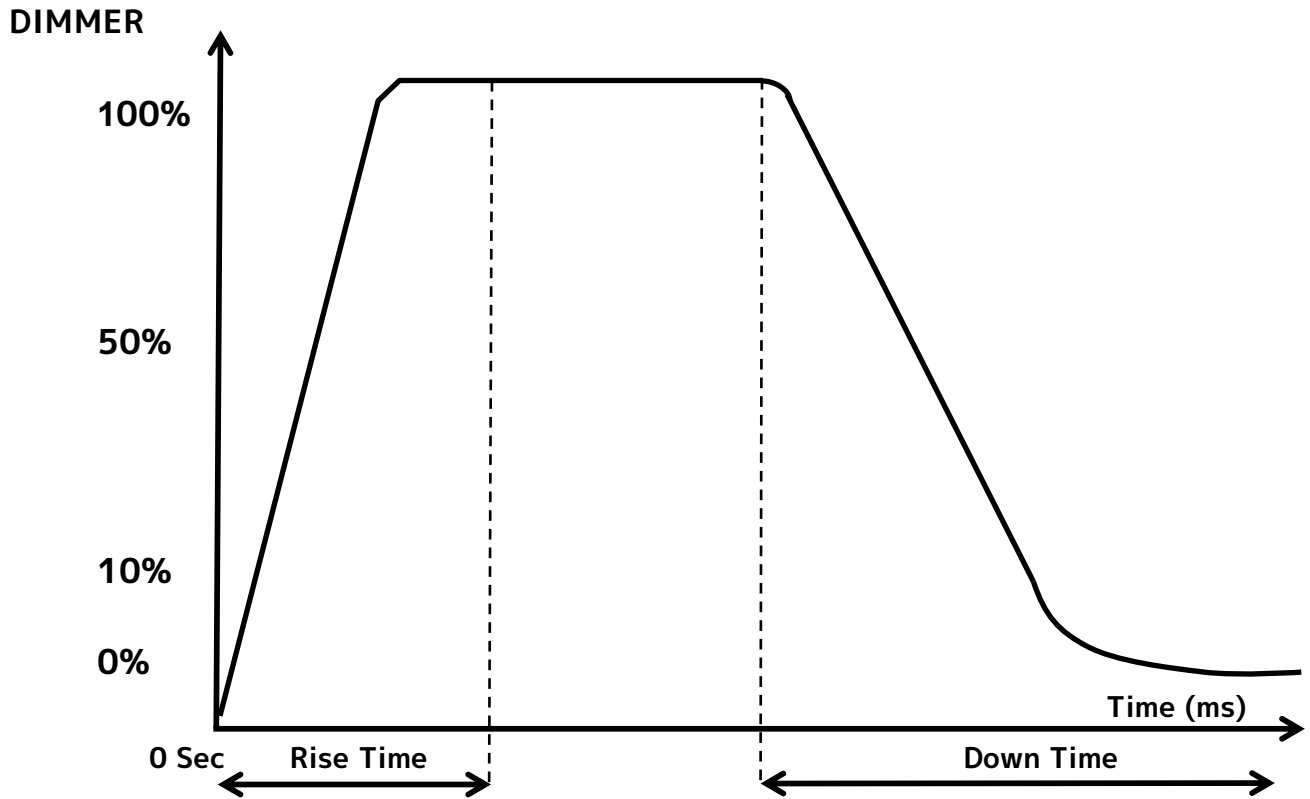

Dimming Curve Ramp Effect	0 sec Fade Time		1 sec Fade Time	
	Rise Time (ms)	Down Time (ms)	Rise Time (ms)	Down Time (ms)
Standard (default)	0	0	0	0
Stage	780	1100	1540	1660
TV	1180	1520	1860	1940
Architectural-	1380	1730	2040	2120
Theatre	1580	1940	2230	2280
Stage 2	0	1100	0	1660

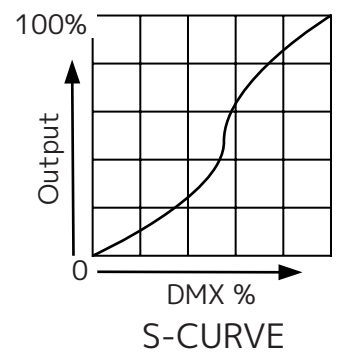
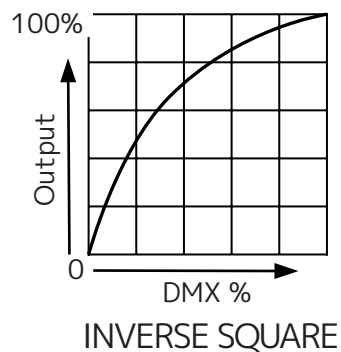
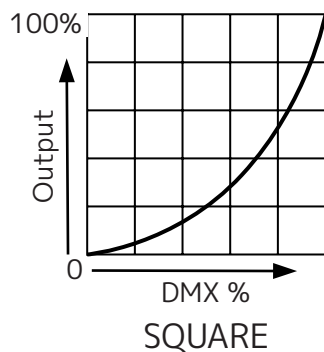
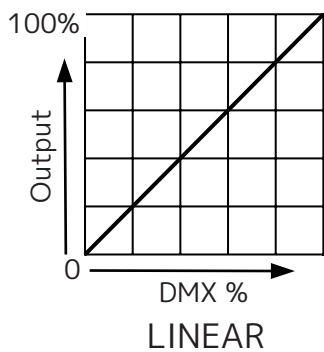

# DMX TRAITS: CHANNEL FUNCTIONS & VALUES

ELATION PROTEUS LUCIUS						
DMX Channel Values / Functions						
Supports Software Versions: $\geq 1.3.0$						
Features subject to change without notice						
MODE/CHANNEL		VALUE	FUNCTION	HOLD TIME	DEFAULT	SNAP
Standard	Extended					
1	1		<b>PAN Movement 8bit:</b>		127	
		0-255	Pan Movement			
2	2		<b>Pan Fine 16bit:</b>		127	
		0-255	Fine control of Pan movement			
3	3		<b>TILT Movement 8bit:</b>		127	
		0-255	Tilt Movement			
4	4		<b>Tilt Fine 16bit:</b>		127	
		0-255	Fine control of Tilt movement			
5	5		<b>Cyan:</b>			
		0-255	Cyan (0-100% Cyan)			
	6		<b>Cyan Fine:</b>			
		0-255	Cyan Fine			
6	7		<b>Magenta:</b>			
		0-255	Magenta (0-100% Magenta)			
	8		<b>Magenta Fine:</b>			
		0-255	Magenta Fine			
7	9		<b>Yellow:</b>			
		0-255	Yellow (0-100% Yellow)			
	10		<b>Yellow</b>			
		0-255	Yellow Fine			
8	11		<b>CTO:</b>			
		0-255	CTO (0-100% CTO)			
	12		<b>CTO Fine</b>			
		0-255	CTO Fine			
9	13		<b>Color Wheel:</b>			X
		0-7	Open			
		8-31	Red			
		32-55	Green			
		56-79	High CRI			
		80-103	Orange			
		104-127	Medium Blue			
		128-189	Clockwise effect from fast to slow			
		190-193	No rotation			
194-255	Counter-clockwise effect from slow to fast					
	14		<b>Color Wheel Fine:</b>			X
		0-255	Fine Control of Color Wheel position			

Features subject to change without notice						
MODE/CHANNEL		VALUE	FUNCTION	HOLD TIME	DEFAULT	SNAP
Standard	Extended					
10	15		<b>Rotating Gobo1</b>			
		0-9	Open			
		10-19	Rot. gobo 1			
		20-29	Rot. gobo 2			
		30-39	Rot. gobo 3			
		40-49	Rot. gobo 4			
		50-59	Rot. gobo 5			
		60-69	Rot. gobo 6			
		70-89	Gobo 1 shake slow to fast			
		90-109	Gobo 2 shake slow to fast			
		110-129	Gobo 3 shake slow to fast			
		130-149	Gobo 4 shake slow to fast			
		150-169	Gobo 5 shake slow to fast			
		170-189	Gobo 6 shake slow to fast			
		190-221	Scroll CW fast to slow			
222-223	Stop					
224-255	Scroll CCW slow to fast					
11	16		<b>Rotating Gobo1 Index, Rotation</b>			
		0-127	Gobo indexing			
		128-189	Clockwise gobo scroll from fast to slow			
		190-193	No rotation			
		194-255	Counter-clockwise gobo scroll from slow to fast			
12	17		<b>Rotating gobo1 fine indexing:</b>			
		0-255	Fine indexing			
13	18		<b>Rotating Gobo2</b>			
		0-9	Open			
		10-19	Rot. gobo 1			
		20-29	Rot. gobo 2			
		30-39	Rot. gobo 3			
		40-49	Rot. gobo 4			
		50-59	Rot. gobo 5			
		60-69	Rot. gobo 6			
		70-77	Rot. gobo 7			
		78-93	Gobo 1 shake slow to fast			
		94-109	Gobo 2 shake slow to fast			
		110-125	Gobo 3 shake slow to fast			
		126-141	Gobo 4 shake slow to fast			
		142-157	Gobo 5 shake slow to fast			
		158-173	Gobo 6 shake slow to fast			
174-189	Gobo 7 shake slow to fast					
190-221	Scroll CW fast to slow					
222-223	Stop					
224-255	Scroll CCW slow to fast					



Features subject to change without notice						
MODE/CHANNEL		VALUE	FUNCTION	HOLD TIME	DEFAULT	SNAP
Standard	Extended					
14	19		<b>Rotating Gobo2 Index, Rotation</b>			
		0-127	Gobo indexing			
		128-189	Clockwise gobo scroll from fast to slow			
		190-193	No rotation			
		194-255	Counter-clockwise gobo scroll from slow to fast			
15	20		<b>Rotating gobo2 fine indexing:</b>			
		0-255	Fine indexing			
16	21		<b>Fixed gobo</b>			
		0-9	Open			
		10-19	Gobo 1			
		20-29	Gobo 2			
		30-39	Gobo 3			
		40-49	Gobo 4			
		50-59	Gobo 5			
		60-69	Gobo 6			
		70-77	Gobo 7			
		78-93	Gobo 1 shake slow to fast			
		94-109	Gobo 2 shake slow to fast			
		110-125	Gobo 3 shake slow to fast			
		126-141	Gobo 4 shake slow to fast			
		142-157	Gobo 5 shake slow to fast			
		158-173	Gobo 6 shake slow to fast			
		174-189	Gobo 7 shake slow to fast			
		190-221	Clockwise gobo scroll from fast to slow			
		222-223	No rotation			
224-255	Counter-clockwise gobo scroll from slow to fast					
	22		<b>Fixed gobo indexing Fine:</b>			
		0-255	Fine indexing			X
17	23		<b>Rotating prism, Prism/Gobo macros:</b>			
		0-63	Open			
		64-127	4 Facet Prism			
		128-135	Macro1			
		136-143	Macro2			
		144-151	Macro3			
		152-159	Macro4			
		160-167	Macro5			
		168-175	Macro6			
		176-183	Macro7			
		184-191	Macro8			
		192--199	Macro9			
		200-207	Macro10			
		208-215	Macro11			
		216-223	Macro12			
		224-231	Macro13			
		232-239	Macro14			
240-247	Macro15					
248-255	Macro16					

Features subject to change without notice						
MODE/CHANNEL		VALUE	FUNCTION	HOLD TIME	DEFAULT	SNAP
Standard	Extended					
18	24		<b>Rotating 4 prism index, rotating gobo rotation:</b>			
		0-127	Prism indexing			
		128-189	Clockwise prism rotation from fast to slow			
		190-193	No rotation			
		194-255	Counter-clockwise prism rotation from slow to fast			
	25		<b>Rotating 4 prism indexing Fine :</b>			
		0-255	Fine indexing			
19	26		<b>Rotating 4 prism linear:</b>			
		0-63	Open			X
		64-255	4 Facet Linear Prism			
20	27		<b>4 Prism Linear index, rotating gobo rotation:</b>			
		0-127	Prism indexing			
		128-189	Clockwise prism rotation from fast to slow			
		190-193	No rotation			
		194-255	Counter-clockwise prism rotation from slow to fast			
	28		<b>4 Prism Linear indexing Fine :</b>			
		0-255	Fine indexing			
21	29		<b>Focus:</b>		127	
		0-255	Focus edge adjustment			
22	30		<b>Focus Fine:</b>		127	
		0-255	Focus adjustment Fine			
23	31		<b>Zoom:</b>		127	
		0-255	Zoom adjustment from small to big			
24	32		<b>Zoom Fine:</b>		127	
		0-255	Zoom adjustment Fine			
	33		<b>Auto Focus :</b>			
		0-50	Auto Focus Off			
		51-100	5m			X
		101-150	7.5m			
		151-200	10m			
		201-255	15m			
	34		<b>AutoFocus Fine:</b>			
		0-255	Continuous adjustment Fine			
25	35		<b>Shutter, strobe:</b>		50	
		0-31	Shutter closed			
		32-63	No function (shutter open)			
		64-95	Strobe effect slow to fast			
		96-127	No function (shutter open)			
		128-159	Pulse-effect in sequences			
		160-191	No function (shutter open)			
		192-223	Random strobe effect slow to fast			
		224-255	No function (shutter open)			
26	36		<b>Dimmer:</b>			
		0-255	Intensity 0 to 100%			
27	37		<b>Dimmer Fine:</b>			
		0-255	Dimmer fine			

Features subject to change without notice.

MODE/CHANNEL		VALUE	FUNCTION	HOLD TIME	DEFAULT	SNAP
Standard	Extended					
28	38		<b>Dim Modes</b>	0		X
		0-20	Standard			
		21-40	Stage			
		41-60	TV			
		61-80	Architectural			
		81-100	Theatre			
		101- 120	Stage 2			
			<b>Dimmer Delay Time</b>			
		121	0s			
		122	0.1s			
		123	0.2s			
		124	0.3s			
		125	0.4s			
		126	0.5s			
		127	0.6s			
		128	0.7s			
		129	0.8s			
		130	0.9s			
		131	1.0s			
		132	1.5s			
		133	2.0s			
		134	3.0s			
		135	4.0s			
136	5.0s					
137	6.0s					
138	7.0s					
139	8.0s					
140	9.0s					
141	10s					
142 - 255	Idle					
29	39		<b>Iris:</b>			
		0-191	Max. diameter to Min.diameter			
		192-223	Pulse opening fast to slow			
		224-255	Pulse closing slow to fast			
40		<b>Iris Fine:</b>				
	0-255	Iris Fine				
30	41		<b>Frost1:</b>			
		0-255	0-100% Linear Light Frost			
31	42		<b>Frost2:</b>			
		0-255	0-100% Linear Wash Frost			
32	43		<b>Animation wheel:</b>			
		0-7	Open			
		8-255	Animation min to max			
33	44		<b>Animation index, animation rotation:</b>			
		0-127	Animation indexing			
		128-189	Clockwise animation rotation from fast to slow			
		190-193	No rotation			
		194-255	Counter-clockwise animation rotation from slow to fast			
45			<b>Speed Of CMY &amp; Color macro Speed:</b>			
		0-255	Speed Max -> Min.			

Features subject to change without notice.

MODE/CHANNEL		VALUE	FUNCTION	HOLD TIME	DEFAULT	SNAP
Standard	Extended					
			<b>Color macros - CMY and color wheel:</b>			
		0-31	OFF			
		32-39	Macro1			
		40-47	Macro2			
		48-55	Macro3			
		56-63	Macro4			
		64-71	Macro5			
		72-79	Macro6			
		80-87	Macro7			
		88-95	Macro8			
		96-103	Macro9			
		104-111	Macro10			
		112-119	Macro11			
		120-127	Macro12			
		128-135	Macro13			
	46	136-143	Macro14			X
		144-151	Macro15			
		152-159	Macro16			
		160-167	Macro17			
		168-175	Macro18			
		176-183	Macro19			
		184-191	Macro20			
		192-199	Macro21			
		200-207	Macro22			
		208-215	Macro23			
		216-223	Macro24			
		224-231	Macro25			
		232-239	Macro26			
		240-247	Macro27			
		248-255	Random CMY			

Features subject to change without notice.

MODE/CHANNEL		VALUE	FUNCTION	HOLD TIME	DEFAULT	SNAP
Standard	Extended					
34	47		<b>Blade 1A</b>			
		0-255	Open to Close			
	48		<b>Blade 1A Fine</b>			
		0-255	Open to Close Fine			
35	49		<b>Blade 1B</b>			
		0-255	Open to Close			
	50		<b>Blade 1B Fine</b>			
		0-255	Open to Close Fine			
36	51		<b>Blade 2A</b>			
		0-255	Open to Close			
	52		<b>Blade 2A Fine</b>			
		0-255	Open to Close Fine			
37	53		<b>Blade 2B</b>			
		0-255	Open to Close			
	54		<b>Blade 2B Fine</b>			
		0-255	Open to Close Fine			
38	55		<b>Blade 3A</b>			
		0-255	Open to Close			
	56		<b>Blade 3A Fine</b>			
		0-255	Open to Close Fine			
39	57		<b>Blade 3B</b>			
		0-255	Open to Close			
	58		<b>Blade 3B Fine</b>			
		0-255	Open to Close Fine			
40	59		<b>Blade 4A</b>			
		0-255	Open to Close			
	60		<b>Blade 4A Fine</b>			
		0-255	Open to Close Fine			
41	61		<b>Blade 4B</b>			
		0-255	Open to Close			
	62		<b>Blade 4B Fine</b>			
		0-255	Open to Close Fine			
42	63		<b>Framing Rotation:</b>			
		0-126	Min (-45 degrees)			
		127-128	Parallel (0 degrees)			
		129-255	Max (+45 degrees)			
	64		<b>Framing Rotation Fine:</b>			
		0-255	Framing Rotation Fine			
	65		<b>Framing Speed:</b>			
		0-255	Speed Max -> Min.			

Features subject to change without notice.

MODE/CHANNEL		VALUE	FUNCTION	HOLD TIME	DEFAULT	SNAP
Standard	Extended					
			<b>Framing Macro:</b>			
		0-7	OFF			
		8-15	Macro1			
		16-23	Macro2			
		24-31	Macro3			
		32-39	Macro4			
		40-47	Macro5			
		48-55	Macro6			
		56-63	Macro7			
		64-71	Macro8			
		72-79	Macro9			
		80-87	Macro10			
		88-95	Macro11			
		96-103	Macro12			
		104-111	Macro13			
		112-119	Macro14			
	66	120-127	Macro15			X
		128-135	Macro16			
		136-143	Macro17			
		144-151	Macro18			
		152-159	Macro19			
		160-167	Macro20			
		168-175	Macro21			
		176-183	Macro22			
		184-191	Macro23			
		192-199	Macro24			
		200-207	Macro25			
		208-215	Macro26			
		216-223	Macro27			
		224-231	Macro28			
		232-239	Macro29			
		240-247	Macro30			
		248-255	Macro31			
			<b>Pan / Tilt Speed:</b>			
		0-225	Max to min speed			
	67	226-235	Blackout by movement			X
		236-245	Blackout by all wheel changing			
		246-255	No function			
			<b>Control:</b>			
		0-19	Color change normal			
		20-29	Color change to any position			
		30-39	Color & gobo change to any position			
		40-44	Low Noise - Mute	0		
		45-49	Low Noise - Studio			
		50-59	Fan Control - Low			
		60-69	Fan Control - High			
		70-79	Fan Control - Auto (Default)			
		80-84	All motor reset			
		85-87	Pan / Tilt reset			
		88-90	Color reset			
		91-93	Gobo reset	3s		
		94-96	Focus and Zoom reset			
		97-99	Other motor reset			
43	68					

Features subject to change without notice

MODE/CHANNEL		VALUE	FUNCTION	HOLD TIME	DEFAULT	SNAP
Standard	Extended					
43	68	100-168	<b>Refresh Rate (Hz)</b>	1s		X
		100	900			
		101	910			
		102	920			
		103	930			
		104	940			
		105	950			
		106	960			
		107	970			
		108	980			
		109	990			
		110	1000			
		111	1010			
		112	1020			
		113	1030			
		114	1040			
		115	1050			
		116	1060			
		117	1070			
		118	1080			
		119	1090			
		120	1100			
		121	1110			
		122	1120			
		123	1130			
		124	1140			
		125	1150			
		126	1160			
		127	1170			
		128	1180			
		129	1190			
		130	1200			
		131	1210			
		132	1220			
		133	1230			
		134	1240			
		135	1250			
		136	1260			
		137	1270			
		138	1280			
		139	1290			
		140	1300			
		141	1310			
142	1320					

Features subject to change without notice.

MODE/CHANNEL		VALUE	FUNCTION	HOLD TIME	DEFAULT	SNAP
Standard	Extended					
43	68	143	1330	1s		X
		144	1340			
		145	1350			
		146	1360			
		147	1370			
		148	1380			
		149	1390			
		150	1400			
		151	1410			
		152	1420			
		153	1430			
		154	1440			
		155	1450			
		156	1460			
		157	1470			
		158	1480			
		159	1490			
		160	1500			
		161	2500			
		162	4000			
		163	5000			
		164	6000			
		165	10000			
		166	15000			
		167	20000			
		168	25000			
		169-170	Gobo Color Correction disable	3s		
		171-172	Gobo Color Correction enable (default)			
		173-174	Hibernation Off			
		175-176	Hibernation			
		177-178	Home Position Before Power Off			
		179-180	Home Position Off			
		181-190	PanTilt Smooth (default)			
		191-200	PanTilt Fast			
		201-210	Dimmer Curve Linear (default)			
		211-220	Dimmer Curve Square			
221-230	Dimmer Curve Inverse Square					
231-240	Dimmer Curve S-Curve					
241	Internal program 1 (scene1~8)					
242	Internal program 2 (scene9~16)					
243	Internal program 3 (scene17~24)					
244	Internal program 4 (scene25~32)					
245	Internal program 5 (scene33~40)					
246	Internal program 6 (scene41~48)					
247	Internal program 7 (scene49~56)					
248-255	Idle					



# ERROR CODES

When power is applied, the unit will automatically enter a "Reset/Test" mode. This mode brings all the internal motors to a home position. If there is an internal problem with one or more of the motors an error code will flash in the display in the form of "XXer" where as XX will represent a function number. For example, when the display shows "0Er" it means there is some type of error with the Pan motor. If there are multiple errors during the start-up process they will all flash in the display. For example: if the fixtures has errors on Channel 1, 2, and 5 all at the same time, you will see the error message "01Er", "02Er", and "05Er" flash repeated 5 times.

If an error does occur during the initial start-up procedure the fixture will self-generate a second reset signal and try to realign all the motors and correct the errors. If the error persists after a second attempt a third attempt will be made. If after a third attempt all the errors have not been corrected the fixture will make the following determinations:

- 3 or More Errors: The fixture cannot function properly with three or more errors therefore the fixture will place itself in a stand-by mode until subsequent repairs can be made.
- Less Than 3 Errors: The fixture has less than 3 errors; therefore, most other functions will work properly. The fixture will attempt to operate normally until the errors can be correct by a technician. The errors in question will remain flashing in the display as a reminder of internal errors.

Error Codes subject to change without notice	
ERROR CODES	DESCRIPTION
Pan Tilt Cyan Megenta Yellow CTO CTB Color Wheel Gobol Gobol_ROT Gobo2 Gobo2_ROT Fixed_Gobo Focus Zoom Prism1 Prism_Rot1 Prism2 Prism_Rot2 Frost1 Frost2 Iris Animation AnimationRot Blade_Rot LED Temp Error Head Temp Error Base Temp Error 3UHeadFan1 Error 3UHeadFan2 Error 3UHeadFan3 Error 3UHeadFan4 Error 3UHeadFan5 Error 5UHeadFan1 Error 8UHeadFan1 Error 11UHeadFan1 Error 11UHeadFan2 Error 11UHeadFan5 Error 11UHeadFan6 Error Base Fan1 Error Base Fan2 Error Base HD Warning. Base HD Higher. Head HD Warning. Head HD Higher. Base HD Error. Head HD Error.	Movement is not located in the default position after the reset. This message will appear after a fixture reset if the magnetic-indexing circuit malfunctions (sensor failed, or magnet is missing) or there is a motor failure (defective motor or a defective motor IC drive on the main PCB).

# SPECIFICATIONS

## SOURCE

580W 6,500K Bright White Hotspot LED Engine  
30,000 Hour Average LED Life\*

\*Test lab conditions. May vary depending on several factors including but not limited to:  
Environmental Conditions, Power/Voltage, Usage Patterns (On-Off Cycling), Control, and Dimming.

## PHOTOMETRIC DATA

33,500 Total Lumen Fixture Output  
CRI 71+ (85+ with HCRI Filter)  
2.5:1 Hotspot Ratio

## EFFECTS

5.5 - 50° Motorized Zoom  
4 Rotating Full Blackout Framing Blades  
+/-45° Continuous Framing Indexing  
Full 360° Bi-Directional Animation Wheel  
4-Facet and Linear Rotating Prisms  
2 Variable Frost Filters (Light and Wash)  
Internal Color, Framing, Prism, and Frost Macros  
Motorized Iris with Variable Pulse Effects  
Variable 16-bit Dimming Curve Modes  
High Speed Electronic Shutter and Strobe  
DMX Controllable LED Refresh Rate

## COLOR

CMY Color Mixing  
Linear CTO Color Correction  
5 Dichroic Colors including High CRI Filter

## GOBOS

3 Gobo Wheels  
6 Rotating Gobo (Wheel #1)  
7 Rotating Gobos (Wheel #2)  
7 Static Gobos (Wheel #3)

## CONTROL/CONNECTIONS

2 DMX Channel Modes (43/68 Ch.)  
16-bit Pan, Tilt and Dimming Control  
Motorized Focus and Auto-Focus Presets  
DMX, RDM, Art-NET, sACN Protocol Support  
(6) Button Touch Control Panel  
Full Color 180° Reversible LCD Menu Display  
Hibernation Mode (Power Save)  
IP65 Locking 5pin XLR Connector In/Out  
IP65 Locking RJ45 Ethernet Connector In/Out  
IP65 Locking Power Connector In  
With Wired Digital Communication Network

## SIZE / WEIGHT

Length: 16.4 in (417mm)  
Width: 14.6 in (370mm)  
Height: 26.6 in (677mm)  
Weight: 89.9 lbs. (40.8 kg)

## ELECTRICAL

AC 120-240V 50/60Hz  
Max Power Consumption 950W  
14°F to 113°F (-10°C to 45°C)  
BTU/hr (+/- 10%) 3239.5

## APPROVALS / RATINGS



Specifications and documentation subject to change without notice.

# DIMENSIONS

\*Drawings not to scale. Specifications and improvements in the design of this unit and this manual are subject to change without notice.

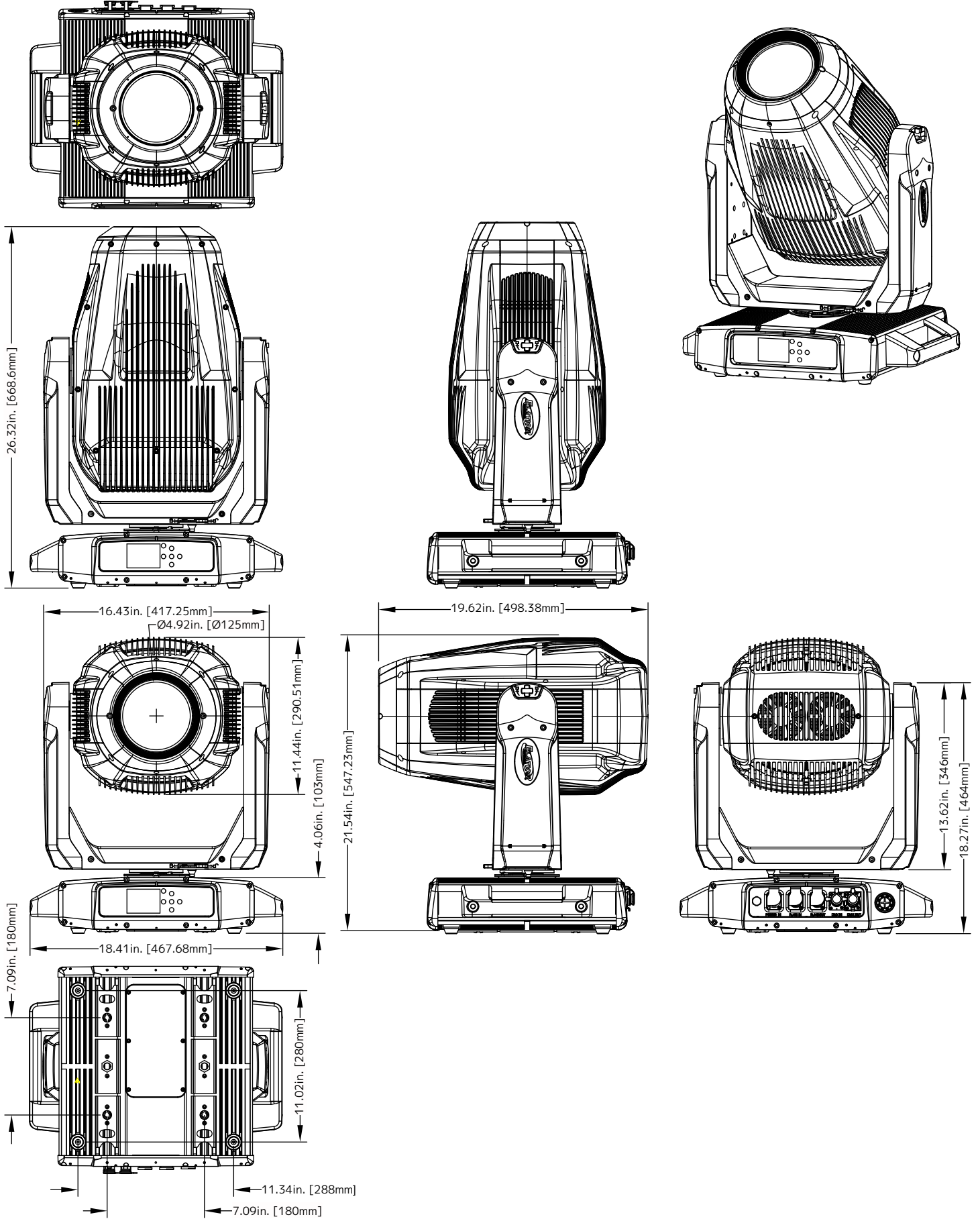

# DIMENSIONS

\*Drawings not to scale. Specifications and improvements in the design of this unit and this manual are subject to change without notice.

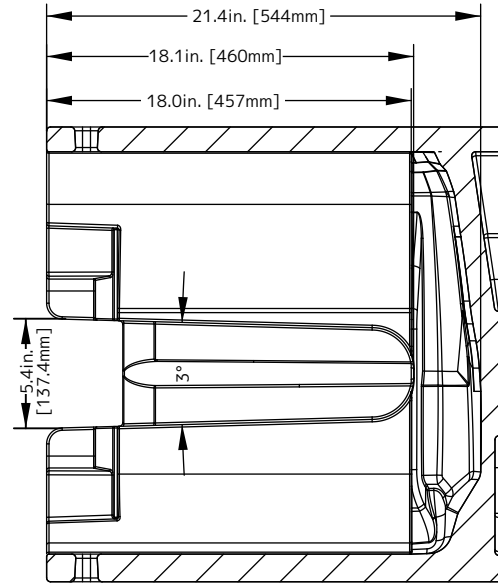
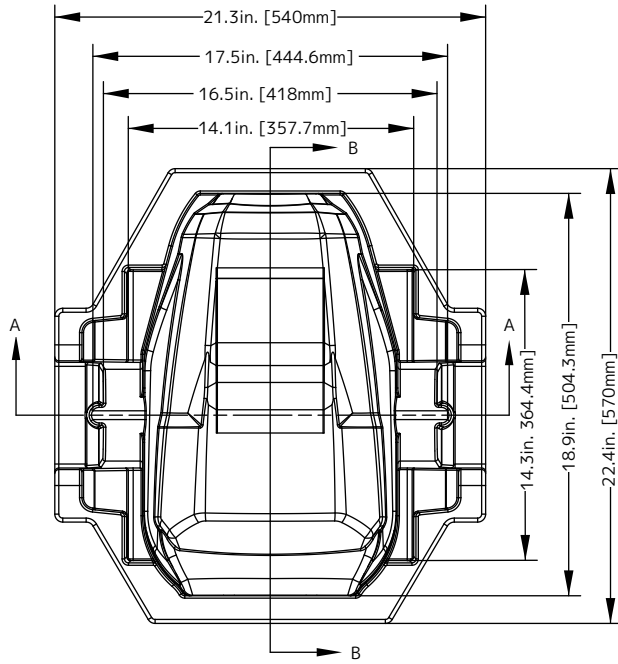

B-B

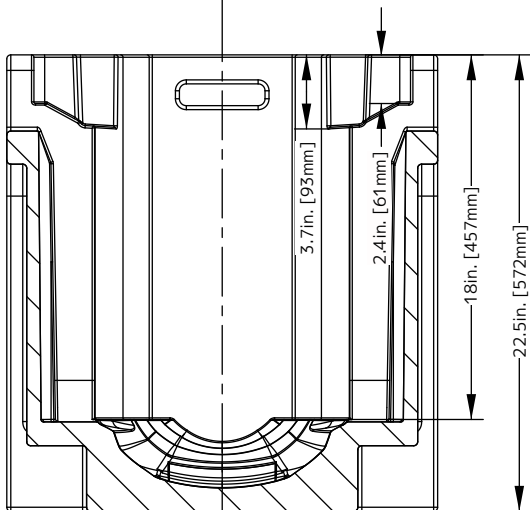

A-A

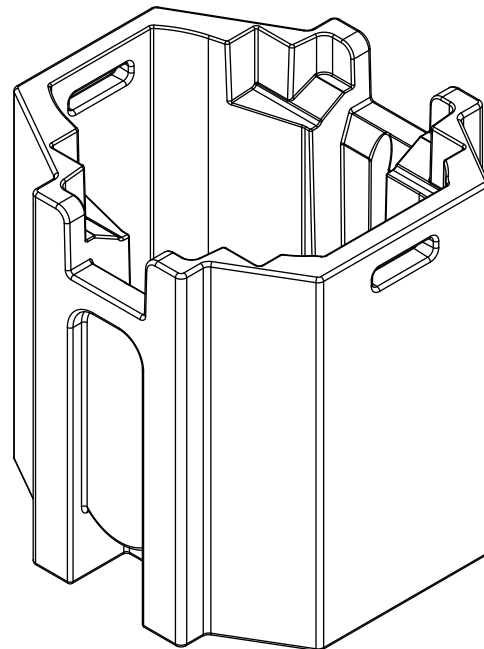
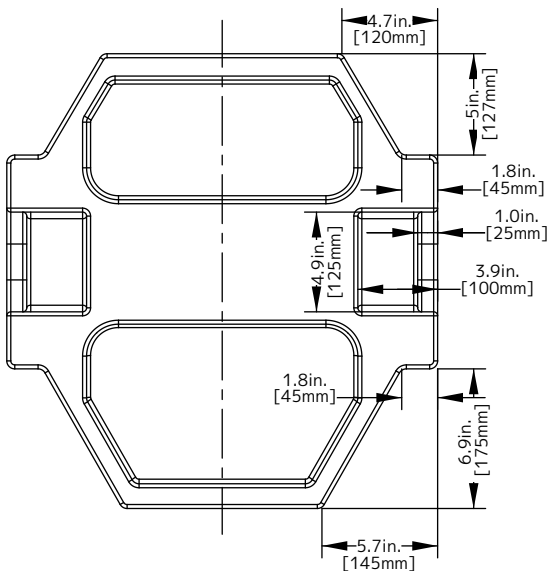

# OPTIONAL ACCESSORIES

ORDER CODE	ITEM
TRIGGER CLAMP	Heavy Duty Wrap Around Hook Style Clamp
SIP126	5 ft. (1.5m) IP65 Twist Lock Power Link Cable
AC5PDMX5PRO	5 ft. (1.5m) 5pin PRO DMX Cable
	Additional Cable Lengths Available

## FCC STATEMENT

This device complies with Part 15 of the FCC Rules. Operation is subject to the following two conditions: (1) this device may not cause harmful interference, and (2) this device must accept any interference received, including interference that may cause undesired operation.

## FCC RADIO FREQUENCY INTERFERENCE WARNINGS & INSTRUCTIONS

This product has been tested and found to comply with the limits as per Part 15 of the FCC Rules. These limits are designed to provide reasonable protection against harmful interference in a residential installation. This device uses and can radiate radio frequency energy and, if not installed and used in accordance with the included instructions, may cause harmful interference to radio communications. However, there is no guarantee that interference will not occur in a particular installation. If this device does cause harmful interference to radio or television reception, which can be determined by turning the device off and on, the user is encouraged to try to correct the interference by one or more of the following methods:

- Reorient or relocate the device.
- Increase the separation between the device and the receiver.
- Connect the device to an electrical outlet on a circuit different from which the radio receiver is connected.
- Consult the dealer or an experienced radio/TV technician for help.

## Energy Saving Matters (EuP 2009/125/EC)

Saving electric energy is a key to help protecting the environment. Please turn off all electrical products when they are not in use. To avoid power consumption in idle mode, disconnect all electrical equipment from power when not in use. Thank you!

