

MAGNOMATIC

CRISP



User Manual

©2020 **MAGMATIC EFFECTS** all rights reserved. Information, specifications, diagrams, images, and instructions herein are subject to change without notice. **MAGMATIC EFFECTS** logo and identifying product names and numbers herein are trademarks of **MAGMATIC EFFECTS**. Copyright protection claimed includes all forms and matters of copyrightable materials and information now allowed by statutory or judicial law or hereinafter granted. Product names used in this document may be trademarks or registered trademarks of their respective companies and are hereby acknowledged. All non-ELATION brands and product names are trademarks or registered trademarks of their respective companies.

MAGMATIC EFFECTS and all affiliated companies hereby disclaim any and all liabilities for property, equipment, building, and electrical damages, injuries to any persons, and direct or indirect economic loss associated with the use or reliance of any information contained within this document, and/or as a result of the improper, unsafe, insufficient and negligent assembly, installation, rigging, and operation of this product.

MAGMATIC EFFECTS | 6122 S. Eastern Ave. | Los Angeles, CA. 90040
323-582-3322 | 323-832-9142 fax | www.elationlighting.com | sales@magmaticeffects.com

Elation Professional B.V. | Junostraat 2 | 6468 EW Kerkrade, The Netherlands
+31 45 546 85 66 | +31 45 546 85 96 fax | www.elationlighting.eu | info@elationlighting.eu

Elation Professional Mexico | AV Santa Ana 30 | Parque Industrial Lerma, Lerma, Mexico 52000
+52 (728) 282-7070

DOCUMENT VERSION

Date	Document Version	Software Version \geq	DMX Channel Mode	Notes
03/04/20	1	1.0	1 / 3 / 5 channels	Initial Release
10/29/20	2	1.0	1 / 3 / 5 channels	Updated Specifications

CONTENTS



General Information	4
Limited Warranty (USA Only)	5
Warranty Returns (USA Only)	6
Safety Guidelines	7
Overview	9
Set Up	10
Control Panel	11
System Menu	12
DMX Channel Functions & Values	14
Dimensional Drawings	15
Trouble Shooting Cleaning	15
Specifications	16

GENERAL INFORMATION



INTRODUCTION

Please read and understand the instructions in this manual carefully and thoroughly before attempting to operate this device. These instructions contain important safety and use information.

This product is intended to be used by professionally trained personnel only and is not suitable for private use.

UNPACKING

Every device has been thoroughly tested and has been shipped in perfect operating condition. Carefully check the shipping carton for damage that may have occurred during shipping. If the carton is damaged, carefully inspect the device for damage, and be sure all accessories necessary to install and operate the device have arrived intact. In the event damage has been found or parts are missing, please contact our customer support team for further instructions. Please do not return this device to your dealer without first contacting customer support. Please do not discard the shipping carton in the trash. Please recycle whenever possible.

BOX CONTENTS

Locking Power Cable

CUSTOMER SUPPORT

Contact **MAGMATIC customer service** for any product related service and support needs. Also visit forums.elationlighting.com with questions, comments or suggestions.

ELATION SERVICE USA - Monday - Friday 8:00am to 4:30pm PST
323-582-3322 | Fax 323-832-9142 | sales@magmaticeffects.com

ELATION SERVICE EUROPE - Monday - Friday 08:30 to 17:00 CET
+31 45 546 85 63 | Fax +31 45 546 85 96 | support@elationlighting.eu

REPLACEMENT PARTS please visit parts.elationlighting.com



IMPORTANT NOTICE!

THERE ARE NO USER SERVICEABLE PARTS INSIDE THIS UNIT. DO NOT ATTEMPT ANY REPAIRS YOURSELF; DOING SO WILL VOID YOUR MANUFACTURER'S WARRANTY. DAMAGES RESULTING FROM MODIFICATIONS TO THIS FIXTURE AND/OR THE DISREGARD OF SAFETY INSTRUCTIONS AND GUIDELINES IN THIS MANUAL VOID THE MANUFACTURER'S WARRANTY AND ARE NOT SUBJECT TO ANY WARRANTY CLAIMS AND/OR REPAIRS.



LIMITED WARRANTY (USA ONLY)

A. Magmatic Effects hereby warrants, to the original purchaser, Magmatic products to be free of manufacturing defects in material and workmanship for a period of two years (730 days) from the original date of purchase. This warranty excludes all product accessories. This warranty shall be valid only if the product is purchased within the United States of America, including possessions and territories. It is the owner's responsibility to establish the date and place of purchase by acceptable evidence, at the time service is sought.

B. For warranty service, send the product only to the Magmatic Effects factory. All shipping charges must be pre-paid. If the requested repairs or service (including parts replacement) are within the terms of this warranty, Magmatic Effects will pay return shipping charges only to a designated point within the United States. If any product is sent, it must be shipped in its original package and packaging material. No accessories should be shipped with the product. If any accessories are shipped with the product, Magmatic Effects shall have no liability what so ever for loss and/or or damage to any such accessories, nor for the safe return thereof.

C. This warranty is void if the product serial number and/or labels are altered or removed; if the product is modified in any manner which Magmatic Effects concludes, after inspection, affects the reliability of the product; if the product has been repaired or serviced by anyone other than the Magmatic Effects factory unless prior written authorization was issued to purchaser by Magmatic Effects; if the product is damaged because not properly maintained as set forth in the product instructions, guidelines and/or user manual.

D. This is not a service contract, and this warranty does not include any maintenance, cleaning or periodic check-up. During the periods as specified above, Magmatic Effects will replace defective parts at its expense, and will absorb all expenses for warranty service and repair labor by reason of defects in material or workmanship. The sole responsibility of Magmatic Effects under this warranty shall be limited to the repair of the product, or replacement thereof, including parts, at the sole discretion of Magmatic Effects. All products covered by this warranty were manufactured after January 1, 1990, and bare identifying marks to that effect.

E. Magmatic Effects reserves the right to make changes in design and/or performance improvements upon its products without any obligation to include these changes in any products theretofore manufactured.

F. No warranty, whether expressed or implied, is given or made with respect to any accessory supplied with the products described above. Except to the extent prohibited by applicable law, all implied warranties made by Magmatic Effects in connection with this product, including warranties of merchantability or fitness, are limited in duration to the warranty periods set forth above. And no warranties, whether expressed or implied, including warranties of merchantability or fitness, shall apply to this product after said periods have expired. The consumer's and/or dealer's sole remedy shall be such repair or replacement as is expressly provided above; and under no circumstances shall Magmatic Effects be liable for any loss and/or damage, direct and/or consequential, arising out of the use of, and/or the inability to use, this product.

G. This warranty is the only written warranty applicable to Magmatic Effects products and supersedes all prior warranties and written descriptions of warranty terms and conditions heretofore published.

WARRANTY RETURNS (USA ONLY)



To obtain warranty service, a Return Materials Authorization (RMA) number must first be obtained from MAGMATIC. It is the Customer's responsibility to provide product proof of purchase and serial number by acceptable evidence such as an invoice copy or an approved MAGMATIC Extended Warranty Certificate ("EWC") and any relevant maintenance records at the time warranty service is sought. Failure to provide acceptable evidence of product proof of purchase or EWC and any relevant maintenance records may be cause for denial of warranty service.

Products returned for warranty service must be sent without any accessories (i.e., power, data, and safety cables, brackets, clamps, rigging hardware, frost filters, gel frames, barn doors, lens, hoses, nozzles, rack mounting hardware, etc.), must be boxed using the original and/or suitable packaging materials (double-box and foam) that provides ample product protection for ground and/or air freight transit, and must be shipped freight pre-paid and insured to MAGMATIC in Los Angeles, CA or an MAGMATIC Authorized Service Center. The RMA number must be clearly written on the outside of the return box, and a brief description of the problem and the RMA number must be documented and included in the box.

Products returned for warranty service without an RMA number clearly marked on the outside of the package will be refused and returned to the shipper at the Customer's expense. Products returned for warranty service, which are received damaged due to inadequate and/or improper packaging and/or due to damage caused by shipping carrier, may incur additional repair charges before warranty service begins and/or may void this warranty. If any product accessories (included and/or optional) are shipped with the product, MAGMATIC and/or the MAGMATIC Authorized Service Center shall have no liability what so ever for the loss and/or damage to any such accessories, nor the safe return thereof. If the requested warranty repairs or service (including parts replacement) are within the terms of this warranty, MAGMATIC will pay return ground transportation shipping charges to a single designated point within the United States.

SAFETY GUIDELINES



To guarantee a smooth operation, it is important to follow all instructions and guidelines in this manual. MAGMATIC is not responsible for injury and/or damages resulting from the misuse of these devices due to the disregard of the information printed in this manual. Only qualified and/or certified personnel should perform installation of these devices and only the original rigging parts included with these devices should be used for installation. Any modifications to these devices and/or the included mounting hardware will void the original manufactures warranty and increase the risk of damage and/or personal injury.



PROTECTION CLASS 1 – DEVICES MUST BE PROPERLY GROUNDED



THERE ARE NO USER SERVICEABLE PARTS INSIDE THESE DEVICES. DO NOT ATTEMPT ANY REPAIRS YOURSELF; DOING SO WILL VOID YOUR MANUFACTURES WARRANTY. DAMAGES RESULTING FROM MODIFICATIONS TO THESE DEVICES AND/OR THE DISREGARD OF SAFETY INSTRUCTIONS AND GUIDELINES IN THIS MANUAL VOID THE MANUFACTURES WARRANTY AND ARE NOT SUBJECT TO ANY WARRANTY CLAIMS AND/OR REPAIRS.



**DO NOT PLUG THIS UNIT INTO A DIMMER PACK!
DO NOT REMOVE THE COVER UNDER ANY CONDITIONS!
KEEP UNIT UPRIGHT!
NEVER OPERATE THIS UNIT WITH THE COVER REMOVED!
UNPLUG POWER DURING LONG PERIODS OF NON-USE
ENSURE TANK AND COOLER ARE EMPTY BEFORE STORAGE OR TRANSPORT!
DO NOT MOVE UNIT WHEN FILLED WITH WATER AND ICE!
DISCONNECT POWER BEFORE ADDING WATER OR PERFORMING MAINTENANCE!**



**INDOOR / DRY LOCATIONS USE ONLY!
DO NOT EXPOSE DEVICES TO RAIN AND/OR MOISTURE!
PLACE UNIT IN A WELL VENTILATED AREA.
ALLOW 40” (100CM) ABOVE AND AROUND THE UNIT FOR PROPER VENTILATION**

SAFETY GUIDELINES



DO NOT attempt installation and/or operation of devices without knowledge how to do so.

DO NOT point or direct the snow output in an unsafe direction.

DO NOT touch the front nozzle when the machine is operating or has just been shut down.

DO NOT permit operation by persons who are not qualified to operate these types of devices.

DO NOT shake devices, avoid brute force when installing and/or operating.

DO NOT operate device if the main power cord has become frayed, crimped and/or damaged. Replace any damaged power cords with a similar power rating.

DO NOT remove or break-off the ground plug from the device power cords.

DO NOT remove or disassemble devices, there are NO user serviceable parts inside.

ALWAYS disconnect devices from main power source before cleaning.

ALWAYS disconnect unit from main power before adding or draining snow fluid.

ALWAYS drain the fluid before moving device.

ALWAYS be sure to keep the device on a level surface.

ALWAYS be sure to use this device in an area that will allow proper ventilation.

ALWAYS disconnect power cords during long periods of non-use.

Power cords should be safely routed and secured so they are not likely pinched.

Use the original packaging and materials to transport this device in for service.

These devices should be serviced by qualified service personnel when:

- The power cords or plugs have become damaged.
- Objects have fallen on and/or liquid has spilled into the devices.
- The devices have been exposed to rain and/or moisture.
- The devices do not operate normally or exhibit a marked change in performance.

OVERVIEW



- 1. Hanging Bracket
- 2. Bracket Knobs
- 3. Output Nozzle
- 4. Safety Cable Attachment Point
- 5. Carrying Handle
- 6. Card Inputs
- 7. Locking 5-Pin XLR Connector In

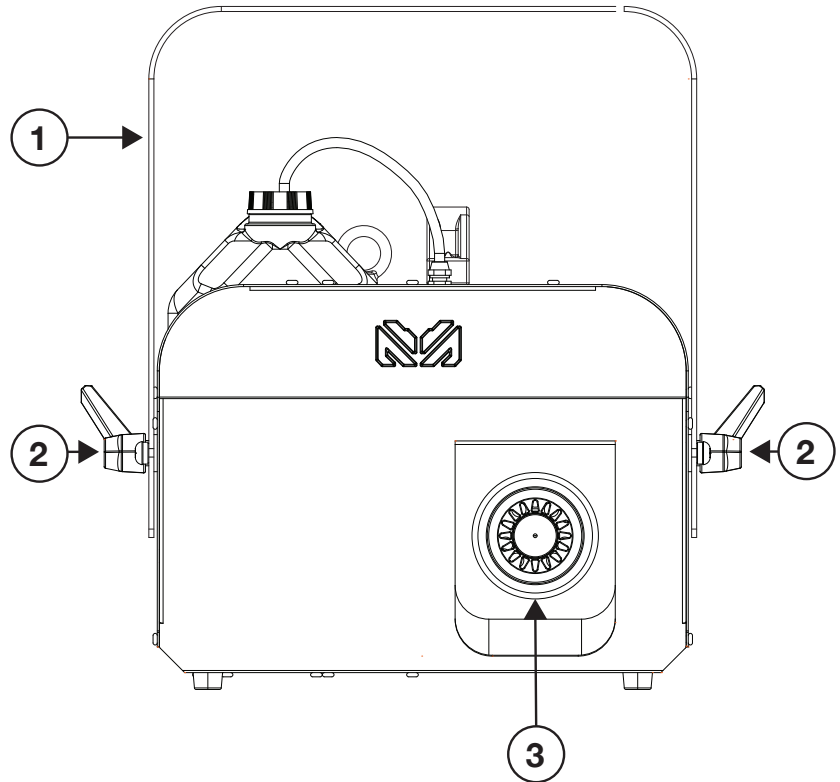

- 8. Locking Power Cable Input
- 9. 15Amp Breaker
- 10. Power Switch
- 11. Locking 5-Pin XLR Connector Out
- 12. Remote Control Connection
- 13. Touch Screen Display
- 14. Fluid Reservoir
- 15. Fluid Feeder Line

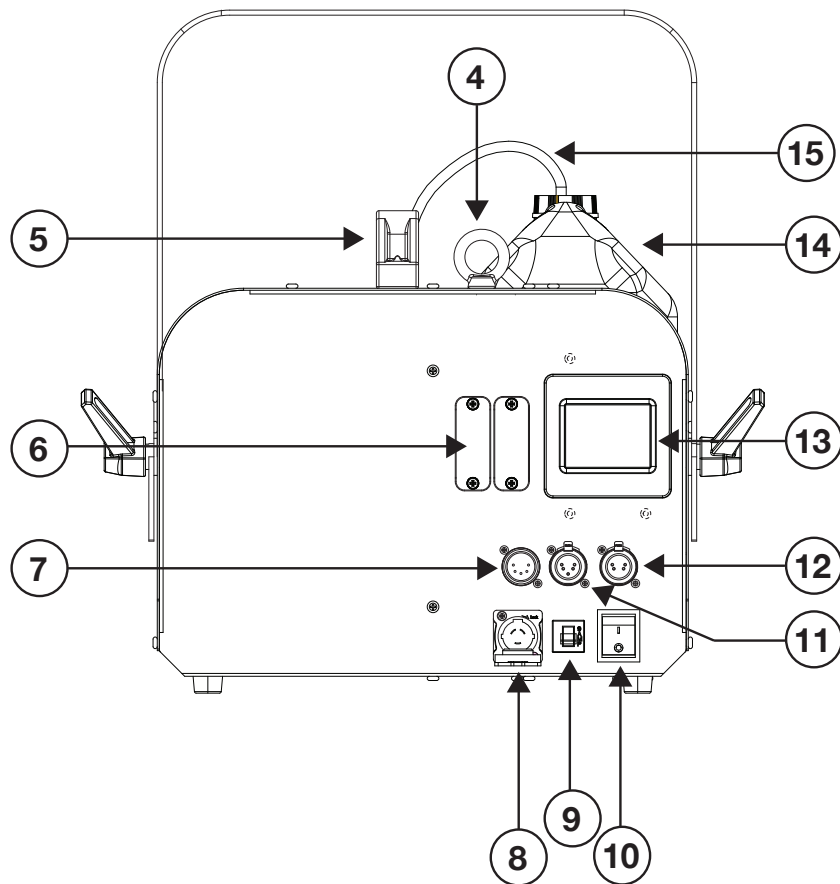

SET UP



1. Open the shipping carton and carefully remove the unit and all included items from the shipping carton.
2. Be sure to remove all the packing material especially around the nozzle.
3. Set the machine on a flat dry surface. Remove the fluid reservoir cap and carefully fill the snow fluid reservoir with Atmosity Premium Snow Fluid. Once the fluid tank is filled, replace and tighten the reservoir cap.
4. Connect the unit to a matching power supply and put the power switch into the “ON” position.
5. To emit snow, select your desired operating mode using the touch screen display. See the control panel and system menu on pages 11-13.

CONTROL PANEL



This fixture includes a system menu with an easy to navigate touch screen control panel where all necessary settings and adjustments are made. When first powering on the fixture, the fixture's main menu will be displayed (**see Main Menu Screen below**).

Press the main menu icon you would like to access. Use the **ENTER** button to access sub menus and use the **UP** and **DOWN** buttons to make adjustments. Press the **ENTER** button to confirm your adjustments. You may exit the main menu at any time without making any adjustments by pressing the **BACK/EXIT** button.

TIMER MENU: The timer sub menu includes snow output adjustment, fan adjustment, duration adjustment, and interval adjustment. To access the **TIMER** adjustment menu, press the **SETTINGS** icon located at the bottom of the screen. Use the **UP** and **DOWN** buttons to make your adjustments and press **ENTER** to confirm. When all settings have been made, press the **PLAY/START** button to begin the timer function.

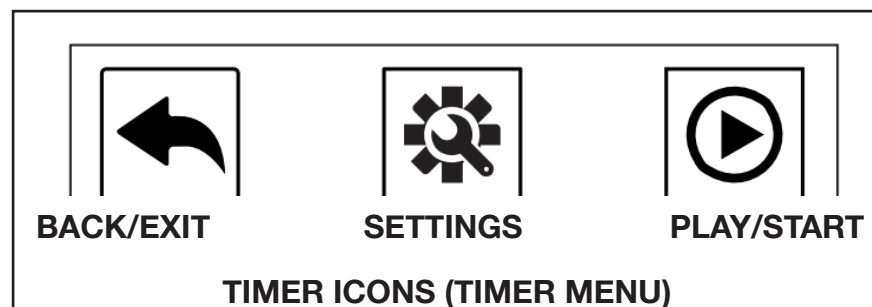
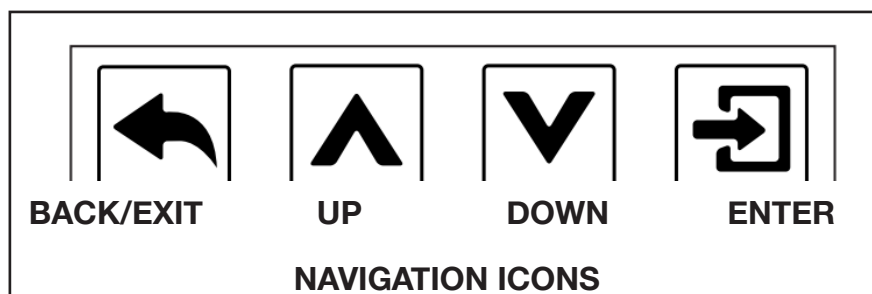
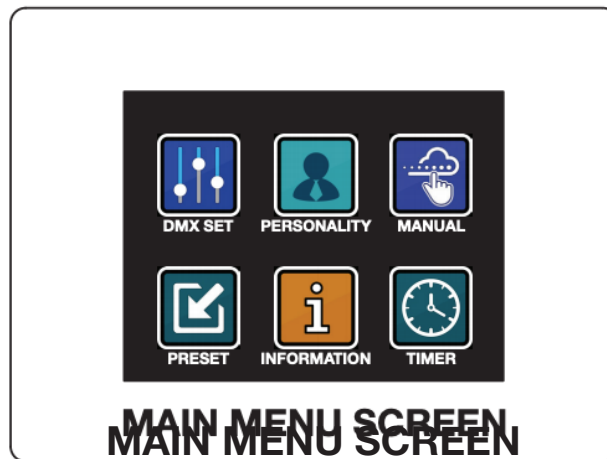

SYSTEM MENU



	DMX SETUP	DMX Addr	001 - 512		DMX Addressing
		DMX Mode	1 CH		DMX Channel Mode Selection
			3 CH		
5 CH					
	PERSONALITY	Wifi Set	Wifi Name	0-XXXX	Displays Wifi Name
			Wifi Passcode	0000000 - 00009999	Wifi Password
			Wifi IP	0-255.0 ~ 255.0 ~ 255.0 ~ 255	Displays Wifi IP
			Wifi Port	0-65535	Network Port
			Reset Network	Complete	Network Connection Reset
				Failed, try again	
		Wifi->DMX & Magfly	On / Off	Magfly Transmit On	
		LCD Set	Screen OFF: Never/10s/40s/1min/2min/5min/10min/20min		Display Blackout Time
		Magfly Set	Magfly Channel: 0-14		Magfly Channel Setting
			Magfly: On / Off		Magfly Activation
		No Fluid	On / Off		Activate/Deactive No Fluid Warning
		RF Learn			
		Last State	Yes / No		Activate/Deactive Last State
Default	Press 'ENTER'		Restore Factory Settings		
	MANUAL	 Snow	1% - 100%	Manual Control	
		 Fan	50% - 100%		
	PRESET	Preset 1 - 10 min duration - 3 min interval - 100% snow - 100% fan		Preset Settings 1 (Not Adjustable)	
		Preset 2 - 5 min duration - 2 min interval - 50% snow - 100% fan		Preset Settings 2 (Not Adjustable)	
		Preset 3 - 3 min duration - 1 min interval - 30% snow - 100% fan		Preset Settings 3 (Not Adjustable)	
12					
CONTINUED ON NEXT PAGE					

SYSTEM MENU



	PRESET (cont'd from prev page)	Preset 4 - 5 min duration - 2 min interval - 10% snow - 100% fan		Preset Settings 4 (Not Adjustable)
		Preset 5 - 3 min duration - 1 min interval - 10% snow - 100% fan		Preset Settings 5 (Not Adjustable)
	INFORMATION	State	Normal / Error	Machine Status
		Slot 1	Null / Magfly / Wifi / RF	Slot 1 Status
		Slot 2	Null / Magfly / Wifi / RF	Slot 2 Status
		Last Control	LCD_auto / LCD_manual / DMX / Wifi / RF / Remote / Error	Current Control Status
		Remote Status	Yes / No	Remote Control Status
		Wifi Connect	Null / Phone / Route / No	Wifi Connection Status
		Wifi IP	No / 0~255, 0~255, 0~255, 0~255	Current Wifi IP Status
		Magfly CH	0-14	Current Magfly Channel Setting
		DMX Addr	1-512	Current DMX Address Setting
		DMX Mode	1 / 3 / 5	Current DMX Ch. Mode Setting
		Timer Output	1% - 100%	Current Timer Output Setting
		Timer Blower	50% / 100%	Current Timer Fan Setting
		Timer Int.	0s - 2500s	Current Timer Interval Setting
		Timer Dur.	0s - 250s	Current Timer Duration Setting
		No Fluid	Normal / Empty	Current Fluid Tank Status
		LCD Ver	V1.2	Current LCD Version
		Sftwr Ver	V1.1	Current Software Version
	TIMER	Snow Output	1% - 100%	Snow Output Setting
		Fan Speed	50% - 100%	Fan Speed Setting
		Interval	0-2500s	Interval Setting
		Duration	0-250s	Duration Setting



DMX CHANNEL FUNCTIONS & VALUES

CHANNEL			DMX VALUES	FUNCTION
1CH	3CH	5CH		
1				Volume
			000 - 005	Off
			006 - 255	1% - 100%
	1	1		On/Off
			000 - 005	Off
			006 - 255	On
	2	2	000 - 255	Volume , 1% - 100%
	3	3		Fan
			000 - 127	50%
			128 - 255	100%
		4		Duration
			000 - 005	0s
			006 - 255	1s - 250s
		5		Interval
			000 - 005	0s
			006 - 255	10s - 2500s

DIMENSIONAL DRAWINGS

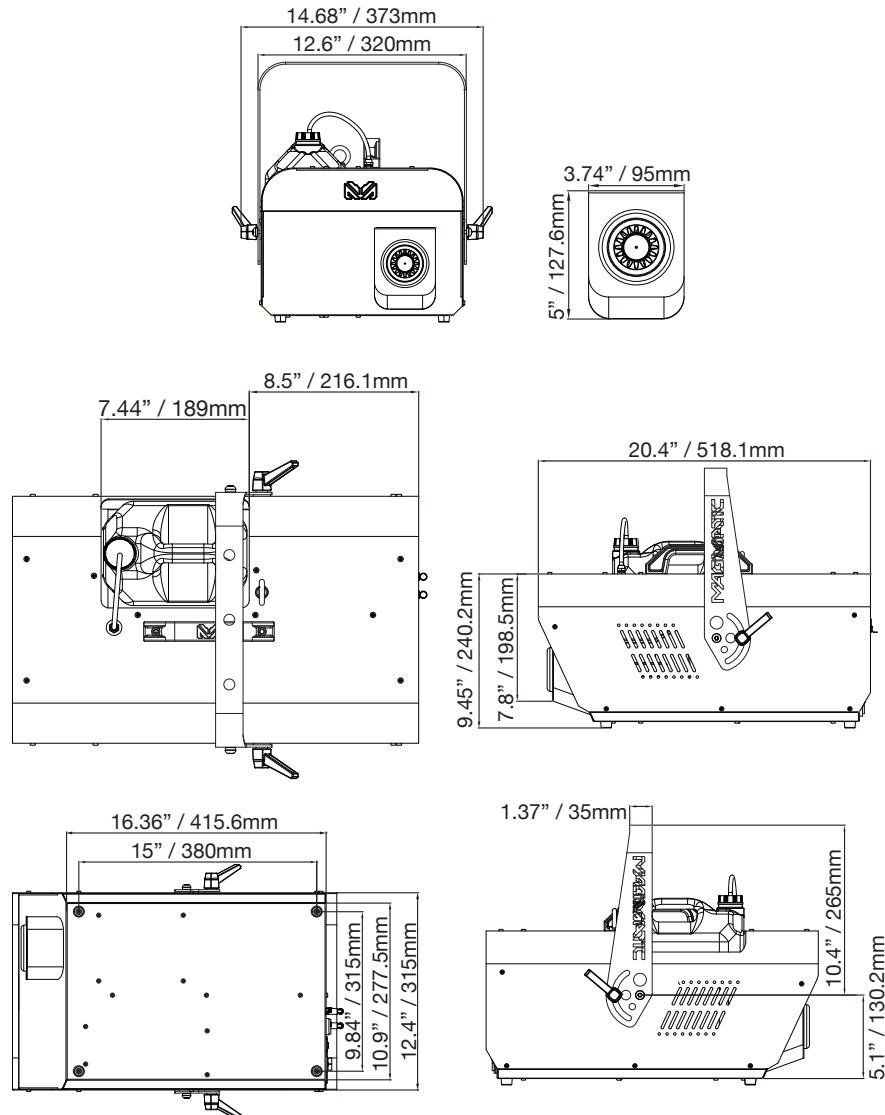

TROUBLE SHOOTING

If you experience low output, pump noise, or no snow output at all, disconnect and discontinue use immediately. Do not attempt to continue to operate as this may damage the machine. Check the fluid level, the breaker, and be sure the wall outlet is sending power. If all of the above appears to be okay, and the unit fails to operate correctly, the unit will require service. Please contact Magmatic Effects.

CLEANING & MAINTENANCE

When storing your snow machine be sure to store it in a cool area. Cover the machine so that dust does not build up on the unit. When storing the machine for long periods of time, it is highly advised to at least run the machine every 2-3 months. Long periods of inactivity can severely shorten the life of your machine. Only run Atmosity Premium Snow Fluid through your machine. **NEVER** run any other liquid solution through your machine. Running anything other than water based **SNOW** fluid will severely damage your machine.



SPECIFICATIONS

Dynamic Effects

Snow Adjustment: 0-100%
Fan Speed Adjustment 50% or 100%
Snow Distance Output: 39.3 ft/ 12m
Self-Clean Function
Auto Shut-off
Advanced HPA (High Pressure Air Pump)

Control

2 Card Inputs (For optional Magfly, MagApp & MagRF cards)
RDM (Remote Device Management)
Control Protocol: DMX512
DMX Modes: 3 (1 / 3 / 5)
On-Board Timing Control
5 Factory Presets
4-pin Wired Remote Input
Touch Screen Display
On-Board Manual Snow Trigger

Connections

Data Connectors: 5-pin locking XLR In/Out
4-pin Connector for optional wired remote
Locking Power Connector

Construction / Physical / Performance

Dimensions (LxWxH): 20.81in x 15.94in x 15.95.0in / 528.8 x 405 x 405.2mm
Weight: 33.5 lbs / 15.2kg
External Visual Fluid Level Detection
Fluid Tank Capacity: 5L
Fluid Consumption: 16.9oz/min / 500ml/min

Electrical

Power Consumption: 1250w
Input Voltage: U.S. Version - 120VAC @ 60Hz and Europe Version - 230 - 240VAC @ 50Hz
Breaker Size: 15A (120V version)
Breaker Size: 9A (230-240V version)

Certifications / Qualifications / Thermal

IP Rating: IP20, dry location
Maximum Temperature (Ambient): 104° F (40° C)
Exterior Surface Temperature: 122° F (50° C)

What's Included

Hanging Bracket
14 AWG Locking Power Cable

Optional Accessories

MagFLY Card
MagAPP Card
MagRF Card
Recommended fluid: Atmosity Premium Snow Fluid. APS-2L, APS-4L, APS-20L, APS-220L (220L Drum *Special Order)