

MAGNOMATIC

CRISP MAX



User Manual

US SKU#:
UPC#:

PSC225
810008261507

©2020 **MAGMATIC EFFECTS** all rights reserved. Information, specifications, diagrams, images, and instructions herein are subject to change without notice. **MAGMATIC EFFECTS** logo and identifying product names and numbers herein are trademarks of **MAGMATIC EFFECTS**. Copyright protection claimed includes all forms and matters of copyrightable materials and information now allowed by statutory or judicial law or hereinafter granted. Product names used in this document may be trademarks or registered trademarks of their respective companies and are hereby acknowledged. All non-MAGMATIC brands and product names are trademarks or registered trademarks of their respective companies.

MAGMATIC EFFECTS and all affiliated companies hereby disclaim any and all liabilities for property, equipment, building, and electrical damages, injuries to any persons, and direct or indirect economic loss associated with the use or reliance of any information contained within this document, and/or as a result of the improper, unsafe, insufficient and negligent assembly, installation, rigging, and operation of this product.

MAGMATIC EFFECTS | 6122 S. Eastern Ave. | Los Angeles, CA. 90040
323-582-3322 | 323-832-9142 fax | www.elationlighting.com | sales@magmaticeffects.com

Elation Professional B.V. | Junostraat 2 | 6468 EW Kerkrade, The Netherlands
+31 45 546 85 66 | +31 45 546 85 96 fax | www.elationlighting.eu | info@elationlighting.eu

Elation Professional Mexico | AC Santa Ana 30 | Parque Industrial Lerma, Lerma, Mexico 52000
+52 (728) 282-7070



DOCUMENT VERSION

Due to additional product features and/or enhancements, an updated version of this document may be available online.

Please check www.elationlighting.com for the latest revision/update of this manual before beginning installation and/or programming.

| Date | Document Version | Software Version | DMX Channel Mode | Notes |
|----------|------------------|------------------|--------------------|---------------------------------|
| 10/20/20 | 1 | 1.1 | 1 / 3 / 5 Channels | Initial Release |
| 10/27/20 | 2 | 1.1 | 1 / 3 / 5 Channels | Updated Set Up & Specifications |

CONTENTS

| | |
|---|----|
| General Information | 4 |
| Limited Warranty (USA Only) | 5 |
| Warranty Returns (USA Only) | 6 |
| Safety Guidelines | 7 |
| Overview | 9 |
| Set Up | 10 |
| Control Panel | 11 |
| System Menu | 12 |
| DMX Channel Functions & Values | 14 |
| Dimensional Drawings Troubleshooting Cleaning & Maintenance | 15 |
| Specifications | 16 |

GENERAL INFORMATION

INTRODUCTION

Please read and understand the instructions in this manual carefully and thoroughly before attempting to operate this device. These instructions contain important safety and use information.

This product is intended to be used by professionally trained personnel only and is not suitable for private use.

UNPACKING

Every device has been thoroughly tested and has been shipped in perfect operating condition. Carefully check the shipping carton for damage that may have occurred during shipping. If the carton is damaged, carefully inspect the device for damage, and be sure all accessories necessary to install and operate the device have arrived intact. In the event that damage has been found or parts are missing, please contact our customer support team for further instructions. Please do not return this device to your dealer without first contacting customer support. Please do not discard the shipping carton in the trash. Please recycle whenever possible.

BOX CONTENTS

Twist-locking Power Cable (x1)
Road Case (x1)
Snow Cannon (x1)
10-meter Hose (x1)
10-meter Power Extension Cable (x1)

CUSTOMER SUPPORT

Contact **MAGMATIC** customer service for any product related service and support needs. Also visit forums.elationlighting.com with questions, comments, or suggestions.

ELATION SERVICE USA - Monday - Friday 8:00am to 4:30pm PST
323-582-3322 | Fax 323-832-9142 | sales@magmaticeffects.com

ELATION SERVICE EUROPE - Monday - Friday 08:30 to 17:00 CET
Voice: +31 45 546 85 63 | Fax: +31 45 546 85 96 | support@elationlighting.eu

REPLACEMENT PARTS: Please visit parts.elationlighting.com



IMPORTANT NOTICE!

THERE ARE NO USER SERVICEABLE PARTS INSIDE THIS UNIT. DO NOT ATTEMPT ANY REPAIRS YOURSELF. DOING SO WILL VOID YOUR MANUFACTURER'S WARRANTY. DAMAGES RESULTING FROM MODIFICATIONS TO THIS FIXTURE AND/OR THE DISREGARD OF SAFETY INSTRUCTIONS AND GUIDELINES IN THIS MANUAL VOID THE MANUFACTURER'S WARRANTY AND ARE NOT SUBJECT TO ANY WARRANTY CLAIMS AND/OR REPAIRS.

LIMITED WARRANTY (USA ONLY)

A. Magmatic Effects hereby warrants, to the original purchaser, Magmatic products to be free of manufacturing defects in material and workmanship for a period of two years (730 days) from the original date of purchase. This warranty excludes discharge lamps and all product accessories. This warranty shall be valid only if the product is purchased within the United States of America, including possessions and territories. It is the owner's responsibility to establish the date and place of purchase by acceptable evidence, at the time service is sought.

B. For warranty service, send the product only to the Magmatic Effects factory. All shipping charges must be pre-paid. If the requested repairs or service (including parts replacement) are within the terms of this warranty, Magmatic Effects will pay return shipping charges only to a designated point within the United States. If any product is sent, it must be shipped in its original package and packaging material. No accessories should be shipped with the product. If any accessories are shipped with the product, Magmatic Effects shall have no liability what so ever for loss and/or or damage to any such accessories, nor for the safe return thereof.

C. This warranty is void if the product serial number and/or labels are altered or removed; if the product is modified in any manner which Magmatic Effects concludes, after inspection, affects the reliability of the product; if the product has been repaired or serviced by anyone other than the Magmatic Effects factory unless prior written authorization was issued to purchaser by Magmatic Effects; if the product is damaged because not properly maintained as set forth in the product instructions, guidelines and/or user manual.

D. This is not a service contract, and this warranty does not include any maintenance, cleaning or periodic check-up. During the periods as specified above, Magmatic Effects will replace defective parts at its expense, and will absorb all expenses for warranty service and repair labor by reason of defects in material or workmanship. The sole responsibility of Magmatic Effects under this warranty shall be limited to the repair of the product, or replacement thereof, including parts, at the sole discretion of Magmatic Effects. All products covered by this warranty were manufactured after January 1, 1990, and bear identifying marks to that effect.

E. Magmatic Effects reserves the right to make changes in design and/or performance improvements upon its products without any obligation to include these changes in any products theretofore manufactured.

F. No warranty, whether expressed or implied, is given or made with respect to any accessory supplied with the products described above. Except to the extent prohibited by applicable law, all implied warranties made by Magmatic Effects in connection with this product, including warranties of merchantability or fitness, are limited in duration to the warranty periods set forth above. And no warranties, whether expressed or implied, including warranties of merchantability or fitness, shall apply to this product after said periods have expired. The consumer's and/or dealer's sole remedy shall be such repair or replacement as is expressly provided above; and under no circumstances shall Magmatic Effects be liable for any loss and/or damage, direct and/or consequential, arising out of the use of, and/or the inability to use, this product.

G. This warranty is the only written warranty applicable to Magmatic Effects products and supercedes all prior warranties and written descriptions of warranty terms and conditions heretofore published.

WARRANTY RETURNS (USA ONLY)

To obtain warranty service, a Return Material Authorization (RMA) number must first be obtained from MAGMATIC. It is the Customer's responsibility to provide product proof of purchase and serial number by acceptable evidence such as an invoice copy or an approved MAGMATIC Extended Warranty Certificate ("EWC") and any relevant maintenance records at the time warranty service is sought. Failure to provide acceptable evidence of product proof of purchase or EWC and any relevant maintenance records may be cause for denial of warranty service.

Products returned for warranty service must be sent without any accessories (i.e., power, data, and safety cables, brackets, clamps, rigging hardware, frost filters, gel frames, barn doors, lenses, hoses, nozzles, rack mounting hardware, etc.), must be boxed using the original and/or suitable packaging materials (double-box and foam) that provides ample product protection for ground and/or air freight transit, and must be shipped freight pre-paid and insured to MAGMATIC in Los Angeles, CA or a MAGMATIC Authorized Service Center. The RMA number must be clearly written on the outside of the return box, and a brief description of the problem and the RMA number must be documented and included in the box.

Products returned for warranty service without an RMA number clearly marked on the outside of the package will be refused and returned to the shipper at the Customer's expense. Products returned for warranty service, which are received damaged due to inadequate and/or improper packaging and/or due to damage caused by the shipping carrier, may incur additional repair charges before warranty service begins and/or may void this warranty. If any product accessories (included and/or optional) are shipped with the product, MAGMATIC and/or the MAGMATIC Authorized Service Center shall have no liability what so ever for the loss and/or damage to any such accessories, nor the safe return thereof. If the requested warranty repairs or service (including parts replacement) are within the terms of this warranty, MAGMATIC will pay return ground transportation shipping charges to a single designated point within the United States.

SAFETY GUIDELINES

This fixture is a sophisticated piece of electronic equipment. To guarantee smooth operation, it is important to follow all instructions and guidelines in this manual. Magmatic Effects is not responsible for injury and/or damages resulting from the misuse of this fixture due to the disregard of the information printed in this manual. Only qualified and/or certified personnel should perform installation of this fixture and only the original parts included with this fixture should be used for installation. Any modifications to the fixture and/or the included mounting hardware will void the original manufacturer's warranty and increase the risk of damage and/or personal injury.



PROTECTION CLASS 1 - FIXTURE MUST BE PROPERLY GROUNDED.



THERE ARE NO USER SERVICEABLE PARTS INSIDE THIS UNIT. DO NOT ATTEMPT ANY REPAIRS YOURSELF. DOING SO WILL VOID YOUR MANUFACTURER'S WARRANTY. DAMAGES RESULTING FROM MODIFICATIONS TO THIS DEVICE AND/OR THE DISREGARD OF SAFETY INSTRUCTIONS AND GUIDELINES IN THIS MANUAL VOID THE MANUFACTURER'S WARRANTY AND ARE NOT SUBJECT TO ANY WARRANTY CLAIMS AND/OR REPAIRS.



**DO NOT PLUG THIS UNIT INTO A DIMMER PACK
DO NOT REMOVE THE COVER UNDER ANY CONDITIONS
KEEP UNIT IN AN UPRIGHT POSITION
NEVER OPERATE THIS UNIT WITH THE COVER REMOVED
UNPLUG FROM POWER DURING LONG PERIODS OF NON-USE
ENSURE TANK IS EMPTY BEFORE STORAGE OR TRANSPORT
DO NOT MOVE WHEN FILLED WITH FLUID
DISCONNECT POWER BEFORE ADDING FLUID OR PERFORMING MAINTENANCE**



**FOR USE IN INDOOR / DRY LOCATIONS ONLY
DO NOT EXPOSE DEVICE TO RAIN AND/OR MOISTURE
PLACE UNIT IN A WELL VENTILATED AREA
ALLOW 40" (100CM) ABOVE AND AROUND THE UNIT FOR PROPER VENTILATION.**

SAFETY GUIDELINES

- Do not attempt installation and/or operation of this device without proper knowledge of how to do so.
- Do not point or direct output in an unsafe direction.
- Do not touch the nozzle while the machine is in operation, or immediately after the device has been shut down.
- Do not shake device, and avoid brute force when installing and/or operating.
- Be sure to save the packing carton in the unlikely event the device may have to be returned for service.
- Do not spill water or other liquids into or on to the device. Be sure that all the fluid is kept inside the fluid reservoir.
- Be sure that the local power outlet matches the required voltage for the device.
- Do not remove components or disassemble the device. There are no user-serviceable parts inside.
- Never connect this device to a dimmer pack.
- Do not attempt to operate this device if it has been damaged in any way.
- Never use this device with the cover removed.
- To reduce risk of electrical shock or fire, do not expose this device to rain or moisture.
- Do not attempt to operate this device if the power cord has been frayed, crimped, and/or damaged. Replace any damaged power cords with new cords of the same power rating.
- Do not remove or break off the ground prong from the electrical cord. This prong is used to reduce the risk of electrical shock and fire in case of an internal short.
- Always disconnect from main power before making any connection, performing cleaning or maintenance, or adding or draining fluid.
- Always drain fluid before moving the device.
- Always be sure to install this device in an area that will allow proper ventilation.
- Always disconnect power cords during long periods of non-use.
- This unit is intended for indoor use only. Use of this product outdoors voids all warranties.
- Always install this unit in a safe and stable matter.
- Please route your power cord out of the way of foot traffic. Power cords should be routed so they are not likely to be walked on, or pinched by items placed upon or against them.
- The device should be serviced by qualified service personnel when:
 - The power cords or plugs have become damaged.
 - Objects have fallen on and/or liquid has spilled into the device.
 - The device has been exposed to rain and/or moisture.
 - The device does not operate normally or exhibits a marked change in performance.

OVERVIEW

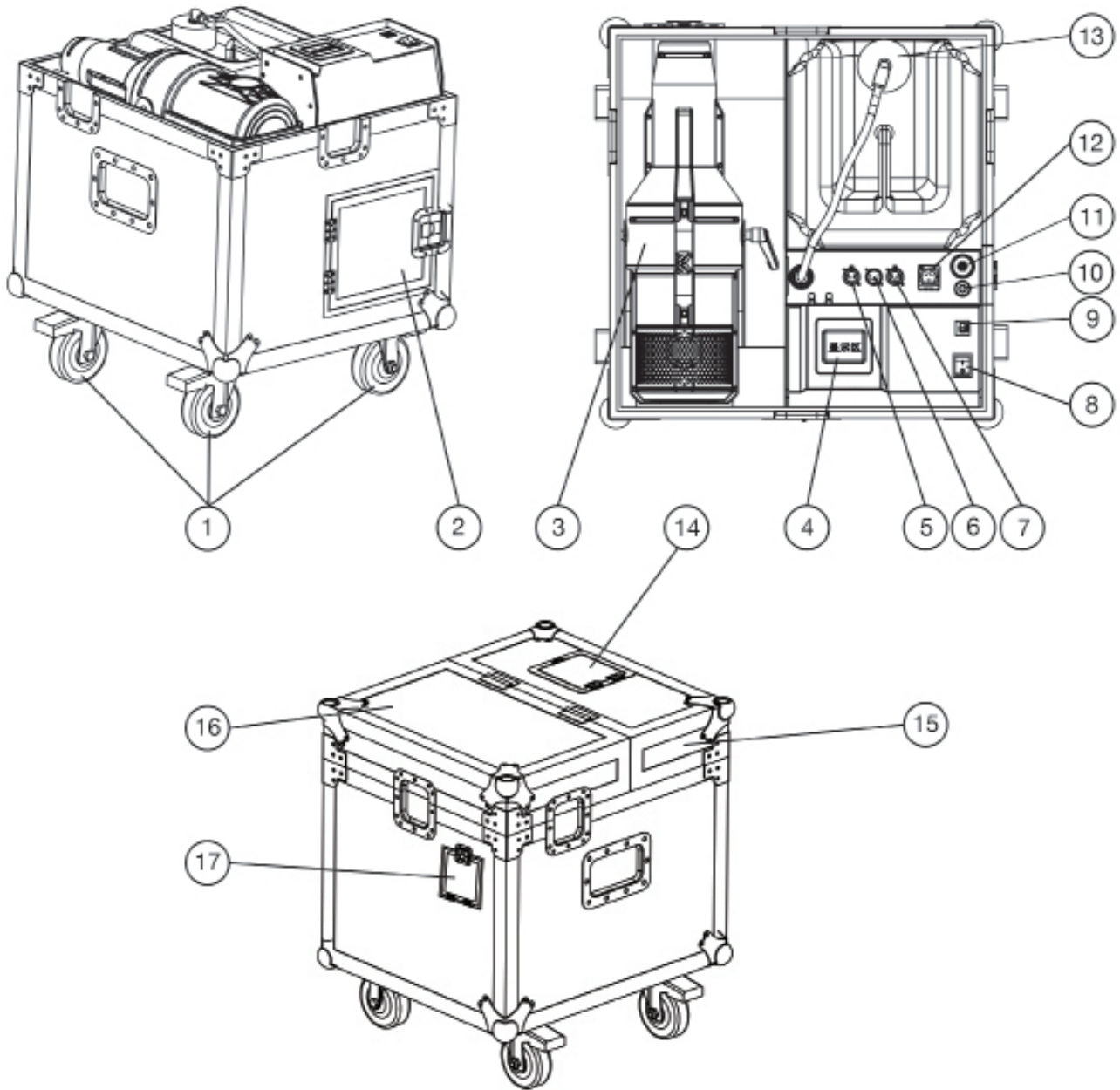

- | | |
|---------------------------|-----------------------------------|
| 1. Casters w/ Brakes (x4) | 10. Snow Cannon Cable Connection |
| 2. Storage Compartment | 11. Snow Cannon Fluid Connection |
| 3. Removable Snow Cannon | 12. Power In |
| 4. Touch Screen Display | 13. Tank Filler Cap |
| 5. Wired Remote Port | 14. Touch Screen Hatch |
| 6. DMX In | 15. Control/Connection Access Lid |
| 7. DMX Out | 16. Tank Filler Access Lid |
| 8. Power Switch | 17. Snow Output Hatch |
| 9. Breaker | |

SET UP

1. Open the shipping carton and carefully remove the device.
2. Be sure to remove ALL the packing material, paying particular attention to the area around the fog outlet vent. Set the device on a flat dry surface.
3. **Make sure that the unit is disconnected from power and the wheels are locked.**
4. Release the three (3) latches on the tank filler access lid, and open the lid. Be careful of the lid hinges and latches so as to avoid pinching your hands or fingers.
5. Unscrew the tank filler cap and fill the tank. **Use only Atmosity Premium Snow Fluid (APS-2L, APS-4L, APS-20L, APS-200L) as specified by the manufacturer. Use of other, non-approved fluids could severely damage your device.**
6. Screw the tank cap back on and close and latch the tank filler access lid.
7. Connect the cable connection and the fluid connection on the connector panel to the matching connectors on the removable snow cannon, using the included 10-m hose and extension cable if needed.

NOTE: When securing the cable connections together, make sure to do so only by turning the thinner nut on the connector containing the MALE PINS!

Twisting the connector containing the female pins may cause damage to the connector and expose the electrical components inside to the elements!

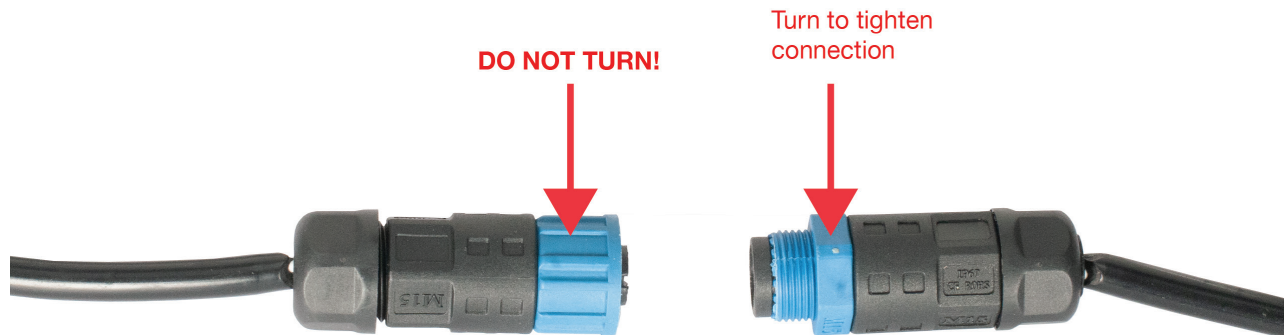

8. Connect the device to power and use the touch screen display to operate the device as desired.





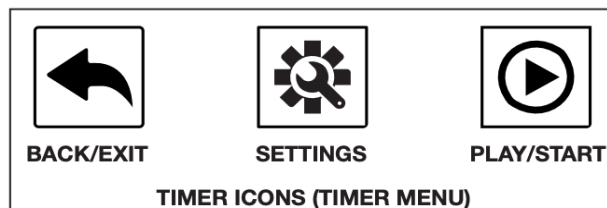
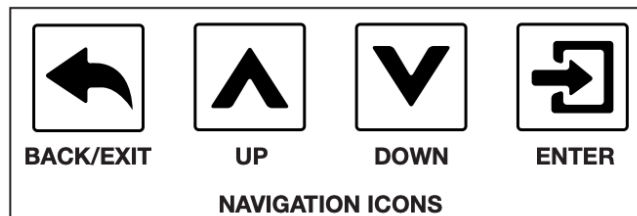
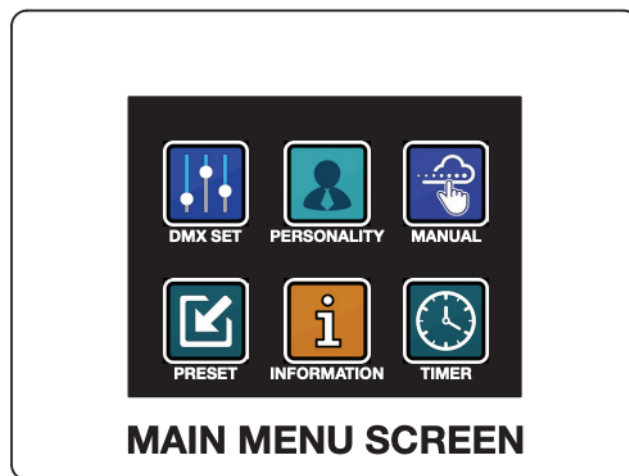

CONTROL PANEL

This fixture includes a system menu with an easy to navigate touch screen control panel where all necessary settings and adjustments are made. When first powering on the fixture, the fixture's main menu will be displayed (**see Main Menu Screen below**).



Press the main menu icon you would like to access. Use the **ENTER** button to access sub menus and use the **UP** and **DOWN** buttons to make adjustments. Press the **ENTER** button to confirm your adjustments. You may exit the main menu at any time without making any adjustments by pressing the **BACK/EXIT** button.



SYSTEM MENU

| | | | | | |
|---|--------------------|---|--|---------------------------------------|------------------------------------|
|  | DMX SETUP | DMX Addr | 001 - 512 | | DMX Addressing |
| | | DMX Mode | 1 CH | | DMX Channel Mode Selection |
| | | | 3 CH | | |
| 5 CH | | | | | |
|  | PERSONALITY | Wifi Set | Wifi Name | 0-XXXX | Displays Wifi Name |
| | | | Wifi Passcode | 0000000 - 00009999 | Wifi Password |
| | | | Wifi IP | 0-255.0 ~ 255.0 ~ 255.0 ~ 255 | Displays Wifi IP |
| | | | Wifi Port | 0-65535 | Network Port |
| | | | Reset Network | Complete | Network Connection Reset |
| | | | | Failed, try again | |
| | | Wifi->DMX & Magfly | On / Off | Magfly Transmit On | |
| | | LCD Set | Screen OFF: Never/10s/40s/1min/2min/5min/10min/20min | | Display Blackout Time |
| | | Magfly Set | Magfly Channel: 0-14 | | Magfly Channel Setting |
| | | | Magfly: On / Off | | Magfly Activation |
| | | No Fluid | On / Off | | Activate/Deactive No Fluid Warning |
| | | RF Learn | | | |
| | | Last State | Yes / No | | Activate/Deactive Last State |
| Default | Press 'ENTER' | | Restore Factory Settings | | |
|  | MANUAL |  Snow | 1% - 100% | Manual Control | |
| | |  Fan | 50% - 100% | | |
|  | PRESET | Preset 1 - 10 min duration - 3 min interval - 100% snow - 100% fan | | Preset Settings 1 (Not Adjustable) | |
| | | Preset 2 - 5 min duration - 2 min interval - 50% snow - 100% fan | | Preset Settings 2 (Not Adjustable) | |
| | | Preset 3 - 3 min duration - 1 min interval - 30% snow - 100% fan | | Preset Settings 3 (Not Adjustable) | |
| CONTINUED ON NEXT PAGE | | | | | |

SYSTEM MENU

| | | | | |
|---|--|--|--|---------------------------------------|
|  | PRESET (cont'd from prev page) | Preset 4 - 5 min duration - 2 min interval - 10% snow - 100% fan | | Preset Settings 4 (Not Adjustable) |
| | | Preset 5 - 3 min duration - 1 min interval - 10% snow - 100% fan | | Preset Settings 5 (Not Adjustable) |
|  | INFORMATION | State | Normal / Error | Machine Status |
| | | Slot 1 | Null / Magfly / Wifi / RF | Slot 1 Status |
| | | Slot 2 | Null / Magfly / Wifi / RF | Slot 2 Status |
| | | Last Control | LCD_auto / LCD_manual / DMX / Wifi / RF / Remote / Error | Current Control Status |
| | | Remote Status | Yes / No | Remote Control Status |
| | | Wifi Connect | Null / Phone / Route / No | Wifi Connection Status |
| | | Wifi IP | No / 0~255, 0~255, 0~255, 0~255 | Current Wifi IP Status |
| | | Magfly CH | 0-14 | Current Magfly Channel Setting |
| | | DMX Addr | 1-512 | Current DMX Address Setting |
| | | DMX Mode | 1 / 3 / 5 | Current DMX Ch. Mode Setting |
| | | Timer Output | 1% - 100% | Current Timer Output Setting |
| | | Timer Blower | 50% / 100% | Current Timer Fan Setting |
| | | Timer Int. | 0s - 2500s | Current Timer Interval Setting |
| | | Timer Dur. | 0s - 250s | Current Timer Duration Setting |
| | | No Fluid | Normal / Empty | Current Fluid Tank Status |
| | | LCD Ver | V1.2 | Current LCD Version |
| | | Sftwr Ver | V1.1 | Current Software Version |
|  | TIMER | Snow Output | 1% - 100% | Snow Output Setting |
| | | Fan Speed | 50% - 100% | Fan Speed Setting |
| | | Interval | 0-2500s | Interval Setting |
| | | Duration | 0-250s | Duration Setting |

DMX CHANNEL FUNCTIONS & VALUES

| CHANNEL | | | DMX VALUES | FUNCTION |
|---------|-----|-----|---------------|----------------------------------|
| 1CH | 3CH | 5CH | | |
| 1 | | | | <i>Volume</i> |
| | | | 000 - 005 | Off |
| | | | 006 - 255 | 1% - 100% |
| | 1 | 1 | | <i>On/Off</i> |
| | | | 000 - 005 | Off |
| | | | 006 - 255 | On |
| | 2 | 2 | 000 - 255 | <i>Volume</i> , 1% - 100% |
| | 3 | 3 | | <i>Fan</i> |
| | | | 000 - 127 | 50% |
| | | | 128 - 255 | 100% |
| | | 4 | | <i>Duration</i> |
| | | | 000 - 005 | 0s |
| | | | 006 - 255 | 1s - 250s |
| | | 5 | | <i>Interval</i> |
| | | | 000 - 005 | 0s |
| | | | 006 - 255 | 10s - 2500s |

DIMENSIONAL DRAWINGS

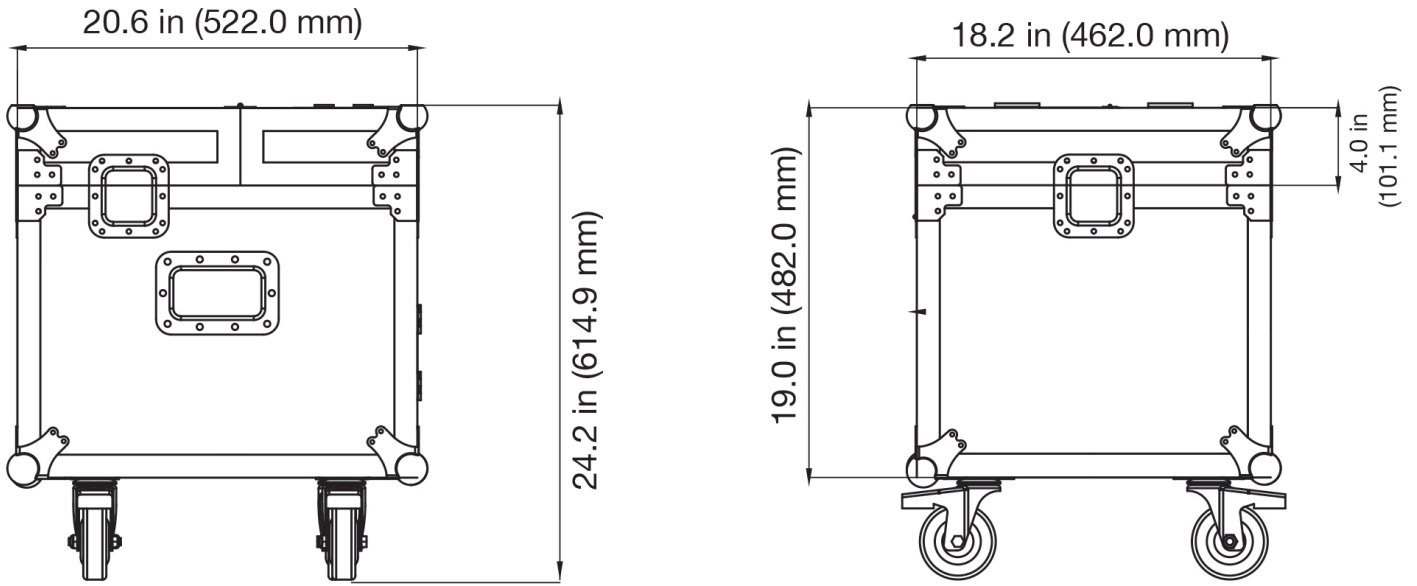

Drawings are not to scale.

TROUBLE SHOOTING

If you experience low output, pump noise, or no snow output at all, disconnect and discontinue use immediately. Do not attempt to continue to operate as this may damage the machine. Check the fluid level, the breaker, and be sure the wall outlet is sending power. If all of the above appears to be okay, and the unit fails to operate correctly, the unit will require service. Please contact Magmatic Effects.

CLEANING & MAINTENANCE

When storing your snow machine be sure to store it in a cool area. Cover the machine so that dust does not build up on the unit. When storing the machine for long periods of time, it is highly advised to at least run the machine every 2-3 months. Long periods of inactivity can severely shorten the life of your machine. Only run Atmosity Premium Snow Fluid through your machine. **NEVER** run any other liquid solution through your machine. Running anything other than water based **SNOW** fluid will severely damage your machine.

SPECIFICATIONS

DYNAMIC EFFECTS:

Snow Adjustment: 0-100%
Fan Speed Adjustment: 50% or 100%
Snow Height Output: 32.8ft / 10m
Snow Distance Output: 39.3ft / 12m

CONTROL:

2 Card Inputs for optional cards
RDM (Remote Device Management)
Control Protocol: DMX512
DMX Modes: 3 (1, 3 & 5 Channel)
On-Board Timing Control
5 Factory Presets
4-pin Wired Remote Input
Touch Screen Display
Manual Trigger via Touch Display

CONNECTIONS:

Data Connector: 5-pin XLR In / Out for DMX connections, 4-pin XLR for optional wired remote.
Locking Power Connector

CONSTRUCTION / PHYSICAL / PERFORMANCE

Dimensions: (LxWxH) 20.86 x 21.26 x 24.21in / 530 x 540 x 615mm
Weight: 77.17lbs / 35kg
Fluid Tank Capacity: 20L
Fluid Consumption: 16.9 fl. oz/min (500ml/min)

COMPATIBLE FLUID

Atmosity Premium Snow Fluid
Models: APS-2L, APS-4L, APS-20L

ELECTRICAL:

Power Consumption: 1250w
Input Voltage: 120V, 230V, 240V, 50 & 60Hz
Breaker Size: 15A (120V Version)
Breaker Size: 9A (230V Version)

CERTIFICATIONS / QUALIFICATIONS / THERMAL

IP Rating: IP20, dry location
Maximum Temperature (Ambient): 104°F (40°C)
Exterior Surface Temperature: 122°F (50°C)

WHAT'S INCLUDED:

Flight Case
14AWG Locking Power Cable
Snow Canon
10-Meter Long Hose

OPTIONAL ACCESSORIES:

MagFLY Card
MagAPP Card
MagRF Card

